



# MMWR<sup>TM</sup>

**Morbidity and Mortality Weekly Report**

[www.cdc.gov/mmwr](http://www.cdc.gov/mmwr)

Recommendations and Reports

May 1, 2009 / Vol. 58 / No. RR-5

## **Compendium of Measures to Prevent Disease Associated with Animals in Public Settings, 2009**

**National Association of State Public Health  
Veterinarians, Inc. (NASPHV)**



**INSIDE: Continuing Education Examination**

**DEPARTMENT OF HEALTH AND HUMAN SERVICES  
CENTERS FOR DISEASE CONTROL AND PREVENTION**

The *MMWR* series of publications is published by the Coordinating Center for Health Information and Service, Centers for Disease Control and Prevention (CDC), U.S. Department of Health and Human Services, Atlanta, GA 30333.

**Suggested Citation:** Centers for Disease Control and Prevention. [Title]. *MMWR* 2009;58(No. RR-#):[inclusive page numbers].

### Centers for Disease Control and Prevention

Richard E. Besser, MD  
*(Acting) Director*

Tanja Popovic, MD, PhD  
*Chief Science Officer*

James W. Stephens, PhD  
*Associate Director for Science*

Steven L. Solomon, MD  
*Director, Coordinating Center for Health Information and Service*

Jay M. Bernhardt, PhD, MPH  
*Director, National Center for Health Marketing*

Katherine L. Daniel, PhD  
*Deputy Director, National Center for Health Marketing*

### Editorial and Production Staff

Frederic E. Shaw, MD, JD  
*Editor, MMWR Series*

Susan F. Davis, MD  
*(Acting) Assistant Editor, MMWR Series*

Robert A. Gunn, MD, MPH  
*Associate Editor, MMWR Series*

Teresa F. Rutledge  
*Managing Editor, MMWR Series*

David C. Johnson  
*(Acting) Lead Technical Writer-Editor*

Catherine B. Lansdowne, MS  
*Project Editor*

Martha F. Boyd  
*Lead Visual Information Specialist*

Malbea A. LaPete  
Stephen R. Spriggs  
*Visual Information Specialists*

Kim L. Bright, MBA  
Quang M. Doan, MBA

Phyllis H. King  
*Information Technology Specialists*

### Editorial Board

William L. Roper, MD, MPH, Chapel Hill, NC, Chairman

Virginia A. Caine, MD, Indianapolis, IN

David W. Fleming, MD, Seattle, WA

William E. Halperin, MD, DrPH, MPH, Newark, NJ

Margaret A. Hamburg, MD, Washington, DC

King K. Holmes, MD, PhD, Seattle, WA

Deborah Holtzman, PhD, Atlanta, GA

John K. Iglehart, Bethesda, MD

Dennis G. Maki, MD, Madison, WI

Sue Mallonee, MPH, Oklahoma City, OK

Patricia Quinlisk, MD, MPH, Des Moines, IA

Patrick L. Remington, MD, MPH, Madison, WI

Barbara K. Rimer, DrPH, Chapel Hill, NC

John V. Rullan, MD, MPH, San Juan, PR

William Schaffner, MD, Nashville, TN

Anne Schuchat, MD, Atlanta, GA

Dixie E. Snider, MD, MPH, Atlanta, GA

John W. Ward, MD, Atlanta, GA

### CONTENTS

Introduction .....	1
Methods .....	2
Enteric (Intestinal) Diseases .....	2
Outbreaks and Lessons Learned .....	2
Sporadic Infections .....	4
Additional Health Concerns .....	4
Injuries .....	4
Exposure to Rabies .....	4
Other Infections .....	5
Recommendations .....	6
Recommendations for Local, State, and Federal Agencies .....	6
Recommendations for Education .....	7
Recommendations for Managing Public-Animal Contact .....	7
Animal Care and Management .....	9
Additional Recommendations .....	9
References .....	10
Appendix A .....	16
Appendix B .....	17
Appendix C .....	18
Appendix D .....	20
Continuing Education Activity .....	CE-1

### Disclosure of Relationship

CDC, our planners, and our content experts wish to disclose they have no financial interests or other relationships with the manufacturers of commercial products, suppliers of commercial services, or commercial supporters. Presentations will not include any discussion of the unlabeled use of a product or a product under investigational use, with the exception of a discussion of off-label use of rabies vaccine in certain animal species for which no licensed rabies vaccine exists. If these species are to be used in a setting where public contact occurs, consultation with a veterinarian regarding off-label use of rabies vaccine is recommended.

**On the Cover:** *Top left:* Public health officials collecting samples at a petting zoo after an outbreak (Photo/Florida Department of Agriculture and Consumer Services). *Top right:* Girl feeding a giraffe at a circus petting zoo (Photo/C. Barton Behravesh). *Bottom left:* Young children watching hatching chicks (Photo/K. Long). *Bottom right:* Girl touching a fox at an Alaska animal exhibit (Photo/C. Sotir-Emond). *Center:* Hand washing after animal contact (Photo/J. Smith).

# Compendium of Measures to Prevent Disease Associated with Animals in Public Settings, 2009

## National Association of State Public Health Veterinarians, Inc. (NASPHV)

Prepared by NASPHV

### Summary

*Certain venues encourage or permit the public to be in contact with animals, resulting in millions of human-animal interactions each year. These settings include county or state fairs, petting zoos, animal swap meets, pet stores, zoologic institutions, circuses, carnivals, educational farms, livestock-birthing exhibits, educational exhibits at schools and child-care facilities, and wildlife photo opportunities. Although human-animal contact has many benefits, many human health problems are associated with these settings, including infectious diseases, exposure to rabies, and injuries. Infectious disease outbreaks reported during the previous decade have been caused by Escherichia coli O157:H7, Salmonella species, Cryptosporidium species, Coxiella burnetii, Mycobacterium tuberculosis, ringworm, and other pathogens. Such infections have substantial medical, public health, legal, and economic effects.*

*This report provides recommendations for public health officials, veterinarians, animal venue staff members, animal exhibitors, visitors to animal venues, physicians, and others concerned with minimizing risks associated with animals in public settings. The recommendation to wash hands is the most important prevention step for reducing the risk for disease transmission associated with animals in public settings. Other critical recommendations are that venues prohibit food in animal areas, venues include transition areas between animal areas and nonanimal areas, visitors receive information about disease risk and prevention procedures, and animals be properly cared for and managed. These updated 2009 guidelines also emphasize risks associated with baby poultry, reptiles, and rodents in public settings, and information about aquatic animal zoonoses has been incorporated.*

### Introduction

Contact with animals in public settings (e.g., fairs, educational farms, petting zoos, and schools) provides opportunities for entertainment and education. The National Association of State Public Health Veterinarians (NASPHV) understands the positive benefits of human-animal contact. However, an inadequate understanding of disease transmission and animal behavior can increase the likelihood of infectious diseases, rabies exposures, injuries, and other health problems among visitors, especially children, in these settings. Zoonotic diseases (i.e., zoonoses) are diseases transmitted between animals and humans. Of particular concern are instances in which zoonoses result in numerous persons becoming ill. During 1991–2005, the number of enteric disease outbreaks associated with animals in public settings increased (1). Since 1996, approximately 100 human infectious disease outbreaks involving animals in

public settings have been reported to CDC (CDC, unpublished data, 2008).

Although eliminating all risk from animal contacts is not possible, this report provides recommendations for minimizing associated disease and injury. NASPHV recommends that local and state public health, agricultural, environmental, and wildlife agencies use these recommendations to establish their own guidelines or regulations for reducing the risk for disease from human-animal contact in public settings. Public contact with animals is permitted in numerous types of venues (e.g., animal displays, petting zoos, animal swap meets, pet stores, zoological institutions, nature parks, circuses, carnivals, educational farms, livestock-birthing exhibits, county or state fairs, child-care facilities or schools, and wildlife photo opportunities). Managers of these venues should use the information in this report in consultation with veterinarians, public health officials, or other professionals to reduce risks for disease transmission.

Guidelines to reduce risk for disease from animals in health-care and veterinary facilities and from service animals (e.g., guide dogs) have been developed (2–6). Although not specifically addressed in this report, the general principles and recommendations in this report are applicable to these settings.

This report has been endorsed by CDC, the Council of State and Territorial Epidemiologists, and the American Veterinary Medical Association.

**Corresponding preparer:** Carina Blackmore, Co-chairperson, NASPHV Animal Contact Compendium Committee, Florida Department of Health, 4052 Bald Cypress Way, Bin A-08, Tallahassee, FL 32330. Telephone: 850-245-4732; Fax: 850-922-8473; e-mail: Carina\_Blackmore@doh.state.fl.us.

## Methods

NASPHV periodically updates the recommendations to prevent disease associated with animals in public settings. The revision includes reviewing recent literature; updating reported outbreaks, diseases, or injuries attributed to human-animal interactions in public settings; and soliciting input from NASPHV members and the public. During October 20–22, 2008, NASPHV members and external expert consultants met at CDC in Atlanta, Georgia. A committee consensus was required to add or modify existing language or recommendations. The 2009 guidelines further emphasize risks associated with baby poultry, reptiles, and rodents in public settings, and information about aquatic animal zoonoses has been incorporated.

## Enteric (Intestinal) Diseases

Infections with enteric bacteria and parasites pose the highest risk for human disease from animals in public settings (7). Healthy animals can harbor human enteric pathogens, many of which have a low infectious dose (8–10). Enteric disease outbreaks among visitors to fairs, farms, petting zoos, and other venues are well documented. Many pathogens have been responsible, including *Escherichia coli* O157:H7 and other Shiga-toxin-producing *E. coli* (STEC), *Salmonella* species, *Cryptosporidium* species, and *Campylobacter* species (11–23). Although reports often document cattle, sheep, or goats (1,13) as sources for infection, poultry (24), rodents (25), reptiles (18) and other domestic and wild animals also are potential sources.

The primary mode of transmission for enteric pathogens is the fecal-oral route. Because animal fur, hair, skin, and saliva (26) often harbor fecal organisms, transmission can occur when persons pet, touch, feed, or are licked by animals. Transmission also has been associated with contaminated animal bedding, flooring, barriers, other environmental surfaces, and contaminated clothing and shoes (12,16,18,27–30). In addition, illness has resulted from fecal contamination of food (31), including raw milk (32–35) and water (36–38).

Removing ill animals (especially those with diarrhea) is necessary but not sufficient to protect animal and human health. Animals carrying human enteric pathogens frequently exhibit no signs of illness. They can shed the organisms intermittently, contaminating the environment (39). Some pathogens live for months or years in the environment (40–44). Because of limitations of laboratory tests, culturing fecal specimens or attempting to identify, screen, and remove infected animals might reduce but cannot eliminate the risk for transmission. Antimicrobial treatment of animals cannot reliably eliminate

infection, prevent shedding, or protect against reinfection. In addition, treatment of animals can prolong shedding and contribute to antimicrobial resistance (45).

Multiple factors increase the probability of disease transmission at animal exhibits. Animals are more likely to shed pathogens because of stress induced by prolonged transportation, confinement, crowding, and increased handling (46–52). Commingling increases the probability that animals shedding organisms will infect other animals (53). The prevalence of certain enteric pathogens is often higher in young animals (54–56), which are frequently used in petting zoos and educational programs. Shedding of STEC and *Salmonella* organisms is highest in the summer and fall, when substantial numbers of traveling animal exhibits, agricultural fairs, and petting zoos are scheduled (51,56,57).

The risk for infection is increased by certain human factors and behaviors, especially in children. These factors include lack of awareness of the risk for disease, inadequate hand washing, lack of close supervision, and hand-to-mouth activities (e.g., use of pacifiers, thumb-sucking, and eating) (58). Children are particularly attracted to animal venues but have increased risk for serious infections. Although farm residents might have some acquired immunity to certain pathogens (59,60), livestock exhibitors have become infected with *E. coli* O157:H7 in fair outbreaks (16; K. Smith, DVM, PhD, Minnesota Department of Health, personal communication, 2008).

The layout and maintenance of facilities and animal exhibits can increase or decrease the risk for infection (61). Factors that increase risk include inadequate hand-washing facilities (62), structural deficiencies associated with temporary food-service facilities (12,15,18), inappropriate flow of visitors, and incomplete separation between animal exhibits and food preparation and consumption areas (63). Other factors include contaminated or inadequately maintained drinking water and sewage- or manure-disposal systems (30, 36–38).

## Outbreaks and Lessons Learned

In 2000, two *E. coli* O157:H7 outbreaks in Pennsylvania and Washington prompted CDC to establish recommendations for enteric disease prevention associated with farm animal contact. Risk factors identified in both outbreaks were direct animal contact and inadequate hand washing (14,64). In the Pennsylvania outbreak, 51 persons (median age: 4 years) became ill within 10 days after visiting a dairy farm. Eight (16%) of these patients acquired hemolytic uremic syndrome (HUS), a potentially fatal consequence of STEC infection. The same strain of *E. coli* O157:H7 was isolated from cattle, patients, and the farm environment. An assessment of the farm environment determined that no areas separate from



the animal contact areas existed for eating and drinking, and the hand-washing facilities were poorly maintained and not configured for children (14).

The protective effect of hand washing and the persistence of organisms in the environment were demonstrated in an outbreak of *Salmonella enterica* serotype Enteritidis infections at a Colorado zoo in 1996. A total of 65 cases (primarily among children) were associated with touching a wooden barrier around a temporary Komodo dragon exhibit. Children who were not ill were significantly more likely to have washed their hands after visiting the exhibit. *S. enterica* serotype Enteritidis was isolated from 39 patients, a Komodo dragon, and the wooden barrier (18).

In 2005, an *E. coli* O157:H7 outbreak among 63 patients, including seven who had HUS, was associated with multiple fairs in Florida. Both direct animal contact and contact with sawdust or shavings were associated with illness (13). Persons who reported feeding animals were more likely to have become ill. Persons were less likely to have become ill if they reported washing their hands before eating or drinking or were aware of the risk for illness before visiting the fair. Among persons who washed their hands with soap and water, creating lather decreased the likelihood of illness, illustrating the value of thorough hand washing. Drying hands on clothing increased the likelihood of illness (65).

During 2000–2001 at a Minnesota children's farm day camp, washing hands with soap after touching a calf and washing hands before going home decreased the likelihood for illness in two outbreaks involving multiple enteric organisms. Implicated organisms for the 84 human infections were *E. coli* O157:H7, *Cryptosporidium parvum*, non-O157 STEC, *S. enterica* serotype Typhimurium, and *Campylobacter jejuni*. These organisms and *Giardia* organisms were isolated from calves. Risk factors for children included caring for an ill calf and getting visible manure on their hands (21).

Disease transmission can occur in the absence of direct animal contact if a pathogen is disseminated in the environment. In an Oregon county fair outbreak, 60 *E. coli* O157:H7 infections occurred, primarily among children (27). Illness was associated with visiting an exhibition hall that housed goats, sheep, pigs, rabbits, and poultry; however, illness was not associated with touching animals or their pens, eating, or inadequate hand washing. *E. coli* O157:H7 was likely disseminated to environmental surfaces via contaminated dust (27).

Enteric pathogens can contaminate the environment and persist in animal housing areas for long periods. For example, *E. coli* O157:H7 can survive in soil for months (37,40,42,66,67). Prolonged environmental persistence of pathogens was documented in 2001 in an Ohio outbreak of *E. coli* O157:H7 infections in which 23 persons became ill at a fair facility after

handling sawdust, attending a dance, or eating and drinking in a barn where animals had been exhibited during the previous week (37). Fourteen weeks after the fair, *E. coli* O157:H7 was isolated from multiple environmental sources within the barn, including from sawdust on the floor and dust on the rafters. Forty-two weeks after the fair, *E. coli* O157:H7 was recovered from sawdust on the floor. In 2004, an outbreak of *E. coli* O157:H7 infections was associated with attendance at the North Carolina State Fair goat and sheep petting zoo (13). Health officials identified 108 patients, including 15 who had HUS. The outbreak strain was isolated from the animal bedding 10 days after the fair was over and from the soil 5 months after the animal bedding and topsoil were removed (67). In 2003, a total of 25 persons acquired *E. coli* O157:H7 at a Texas agricultural fair; seven cases were culture confirmed. The strain cultured from patients also was found in fair environmental samples 46 days after the fair ended (16).

Improper facility design and inadequate maintenance can increase risk for infection, as illustrated by one of the largest waterborne outbreaks in the United States (37,38). In 1999, approximately 800 suspected cases of infection with *E. coli* O157:H7 and *Campylobacter* species were identified among attendees at a New York county fair, where unchlorinated water supplied by a shallow well was used by food vendors to make beverages and ice (38). Temporary facilities such as those associated with fairs are particularly vulnerable to design flaws (13,18). Such venues include those that add an animal display or petting zoo to attract children to zoos, festivals, roadside attractions, farm stands, farms where persons can pick their own produce, and Christmas tree lots. In 2005, an *E. coli* O157:H7 outbreak in Arizona was associated with a temporary animal contact exhibit at a municipal zoo (13). A play area for children was immediately adjacent to and downhill from the petting zoo facility. The same strain of *E. coli* O157:H7 was found both in children and 12 petting zoo animals. Child-care facility and school field trips to a pumpkin patch with a petting zoo resulted in 44 cases of *E. coli* O157:H7 infection in British Columbia, Canada (15). The same strain of *E. coli* O157:H7 was found both in children and in a petting zoo goat. Running water and signs recommending hand washing were not available, and alcohol hand sanitizers were at a height that was unreachable for some children. In New York, 163 persons became ill with STEC O111:H8, *Cryptosporidium* species, or both at a farm stand that sold unpasteurized apple cider and had a petting zoo with three calves (68). Stools from two calves were Shiga-toxin 1 positive.

Several outbreaks have occurred because of failure to understand and properly implement disease-prevention recommendations. Following a Minnesota outbreak of cryptosporidiosis with 31 ill students at a school farm program, specific

recommendations provided to teachers were inadequately implemented (19), and a subsequent outbreak occurred with 37 illnesses. Hand-washing facilities and procedures were inadequate. Coveralls and boots were dirty, cleaned infrequently, and handled without repeat hand washing.

Outbreaks have resulted from contaminated animal products used for educational activities in schools. Salmonellosis outbreaks associated with dissection of owl pellets have been documented in Minnesota (69) and Massachusetts (C. Brown, DVM, Massachusetts Department of Public Health, personal communication, 2008). In Minnesota, risk factors for infection included inadequate hand washing, use of food service areas for the activity, and improper cleaning of contact surfaces. Persons in a middle school science class were among those infected in a multistate salmonellosis outbreak associated with frozen rodents purchased from the same Internet supplier to feed pet snakes (25).

During 2005–2008, several infectious disease outbreaks were caused by contact with animals and animal products. Although not primarily associated with public settings, the outbreaks have implications for animal contact venues. Turtles and other reptiles, rodents, and baby poultry (e.g., chicks and ducklings) have long been recognized as a source of human *Salmonella* infections (24,70–77). Since 2006, at least three large multistate outbreaks have been linked to contact with small turtles, including a fatal case in an infant (76,77). Since 2005, at least three multistate outbreaks linked to baby poultry from mail-order hatcheries have been identified; ill persons included those who reported contact with baby poultry at a feed store, school classroom, fair, or petting zoo (75). During 2006–2008, a total of 79 human *Salmonella enterica* serotype Schwarzengrund infections were linked to multiple brands of contaminated dry dog and cat food produced at a plant in Pennsylvania (78,79). Contaminated pig ear treats and pet treats containing beef and seafood also have been linked to human *Salmonella* infections (80–83).

Multidrug-resistant human *Salmonella* infections have been linked to contact with contaminated water from home aquariums containing tropical fish (84,85). A single case of *Plesiomonas shigelloides* infection in a Missouri infant was identified, and the organism was subsequently isolated from a babysitter's aquarium (86). A survey of tropical fish tanks in Missouri found that four (22%) of 18 tanks yielded *P. shigelloides* from three pet stores. These findings have implications for risk for infection from aquatic exhibits (e.g., aquariums and aquatic touch tanks).

## Sporadic Infections

Sporadic infections also have been associated with animal environments. A study of sporadic *E. coli* O157:H7 infections in the United States determined that persons who became ill, especially children, were more likely than persons who did not become ill to have visited a farm with cows (87). Additional studies also documented an association between *E. coli* O157:H7 infection and visiting a farm (88) or living in a rural area (89). Studies of human cryptosporidiosis have documented contact with cattle or visiting farms as risk factors for infection (59,90,91). In addition, a case-control study identified multiple factors associated with *Campylobacter* infection, including consumption of raw milk and contact with farm animals (92).

## Additional Health Concerns

Although enteric diseases are the most commonly reported illnesses associated with animals in public settings, other health risks exist. For example, allergies can be associated with animal dander, scales, fur, feathers, urine, and saliva (93–99). Additional health concerns include injuries, exposure to rabies, and infections other than enteric diseases.

## Injuries

Injuries associated with animals in public settings include bites, kicks, falls, scratches, stings, crushing of the hands or feet, and being pinned between the animal and a fixed object. These injuries have been associated with big cats (e.g., tigers), monkeys, and other domestic, wild, and zoo animals. The settings have included public stables, petting zoos, traveling photo opportunities, schools, children's parties, and animal rides (M. Eidson, DVM, New York State Department of Health, personal communication, 2003; J.B. Bender, DVM, University of Minnesota, personal communication, 2003; M.T. Jay-Russell, DVM, California Department of Health, personal communication, 2003; G.L. Swinger, DVM, Tennessee Department of Health, personal communication, 2003). For example, a Kansas teenager was killed while posing for a photograph with a tiger being restrained by its handler at an animal sanctuary (100). In Texas, two high school students were bitten by a cottonmouth snake that was used in a science class after being misidentified as a nonvenomous species (W. Garvin, Caldwell Zoo, Texas, personal communication, 2008).

## Exposure to Rabies

Persons who have contact with rabid mammals can be exposed to the rabies virus through a bite or when mucous

membranes or open wounds become contaminated with infected saliva or nervous tissue. Although no human rabies deaths caused by animal contact in public settings have been reported, multiple rabies exposures have occurred, requiring extensive public health investigations and medical follow-up. For example, thousands of persons have received rabies postexposure prophylaxis (PEP) after being exposed to rabid or potentially rabid animals, including bats, cats, goats, bears, sheep, horses, and dogs, at various venues: a pet store in New Hampshire (101), a county fair in New York State (102), petting zoos in Iowa (103,104) and Texas (J.H. Wright, DVM, Texas Department of Health, personal communication, 2004), school and rodeo events in Wyoming (62), a horse show in Tennessee, and summer camps in New York (105). Substantial public health and medical care challenges associated with potential mass rabies exposures include difficulty in identifying and contacting persons, correctly assessing exposure risks, and providing timely medical prophylaxis. Prompt assessment and treatment are critical to prevent this disease, which is usually fatal.

## Other Infections

Multiple bacterial, viral, fungal, and parasitic infections have been associated with animal contact, and the infecting organisms are transmitted through various modes. Infections from animal bites are common and frequently require extensive treatment or hospitalization. Bacterial pathogens associated with animal bites include *Pasteurella* species, *Francisella tularensis* (106), *Staphylococcus* species, *Streptococcus* species, *Capnocytophaga canimorsus*, *Bartonella henselae* (cat-scratch disease), and *Streptobacillus moniliformis* (rat-bite fever). Certain monkey species (especially macaques) that are kept as pets or used in public exhibits can be infected with simian herpes B virus; they might be asymptomatic or have mild oral lesions. Human exposure through monkey bites or bodily fluids can result in fatal meningoencephalitis (107,108).

Skin contact with animals in public settings is also a public health concern. In 1995, 15 cases of ringworm (club lamb fungus) caused by *Trichophyton* species and *Microsporum gypsum* were documented among owners and family members who exhibited lambs in Georgia (109). In 1986, ringworm in 23 persons and multiple animal species was traced to a *Microsporum canis* infection in a hand-reared zoo tiger cub (110). Orf virus infection (i.e., contagious ecthyma, or sore mouth) has occurred after contact with sheep at a public setting (111). Orf virus infection also has been described in goats and sheep at a children's petting zoo (112) and in a lamb used for an Easter photo opportunity (M. Eidson, DVM, New York State Department of Health, personal communication, 2003).

In the 1970s, after handling various species of infected exotic animals, a zoo attendant experienced an extensive papular skin rash from a cowpox-like virus (113). In 2003, multiple cases of monkeypox occurred among persons who had contact with infected prairie dogs either at a child-care center (114,115) or a pet store (J.J. Kazmierczak, DVM, Wisconsin Department of Health and Family Services, personal communication, 2004). Aquatic animals and their environment also have been associated with cutaneous infections (116). For example, *Mycobacterium marinum* infections have been described among persons owning or cleaning fish tanks (117,118).

Ectoparasites and endoparasites pose concerns when humans and exhibit animals interact. *Sarcoptes scabiei* is a skin mite that infests humans and animals, including swine, dogs, cats, foxes, cattle, and coyotes (119,120). Although human infestation from animal sources is usually self-limiting, skin irritation and itching might occur for multiple days and can be difficult to diagnose (120,121). Bites from avian mites have been reported in association with pet gerbils in school settings (122). Animal flea bites to humans increase the risk for infection or allergic reaction. In addition, fleas can carry a tapeworm species that can infect children who swallow the flea (123,124). Animal parasites also can infect humans who ingest soil or other materials contaminated with animal feces or who come into contact with contaminated soil. Parasite control through veterinary care and proper husbandry combined with hand washing reduces the risks associated with ectoparasites and endoparasites (125).

Tuberculosis is another disease associated with certain animal settings. In 1996, 12 circus elephant handlers at an exotic animal farm in Illinois were infected with *Mycobacterium tuberculosis*; one handler had signs consistent with active disease after three elephants died of tuberculosis. Medical history and testing of the handlers indicated that the elephants had been a probable source of exposure for most of the human infections (126). During 1989–1991 at a zoo in Louisiana, seven animal handlers who were previously negative for tuberculosis tested positive after a *Mycobacterium bovis* outbreak in rhinoceroses and monkeys (127). In 2003, the U.S. Department of Agriculture (USDA) developed guidelines regarding removal of tuberculosis-infected animals from public settings because of the risk for exposure to the public (128).

Zoonotic pathogens also can be transmitted by direct or indirect contact with reproductive fluids, aborted fetuses, or newborns from infected dams. Live-birthing exhibits, usually involving livestock (e.g., cattle, pigs, goats, or sheep), are popular at agricultural fairs. Although the public usually does not have direct contact with animals during birthing, newborns and their dams might be available for petting afterward. Q fever (*Coxiella burnetii*), leptospirosis, listeriosis, brucellosis,



and chlamydiosis are serious zoonoses that can be acquired through contact with reproductive materials (129).

*C. burnetii* is a rickettsial organism that most frequently infects cattle, sheep, and goats. The disease can cause abortion in animals, but more frequently the infection is asymptomatic. During birthing, infected animals shed substantial numbers of organisms, which can become aerosolized. Most persons exposed to *C. burnetii* develop an asymptomatic infection, but clinical illness can range from an acute influenza-like illness to life-threatening endocarditis. A Q fever outbreak involving 95 confirmed cases and 41 hospitalizations was linked to goats and sheep giving birth at petting zoos in indoor shopping malls (130). Indoor-birthing exhibits might pose an increased risk for Q fever transmission because of inadequate ventilation.

*Chlamydophila psittaci* infections cause respiratory disease and are usually acquired from psittacine birds (131). For example, an outbreak of *C. psittaci* pneumonia occurred among the staff members Copenhagen Zoological Garden (132). On rare occasions, chlamydial infections acquired from sheep, goats, and birds result in reproductive problems in women (131,133,134).

Swine influenza virus (H1N1) was the suspected cause of a respiratory outbreak in swine and swine exhibitors at an Ohio county fair in 2007. The virus was isolated from swine and from a man and his daughter, who were both exhibitors at the fair (135).

## Recommendations

Guidelines from multiple organizations were used to create the recommendations in this report (136–138). Although no federal U.S. laws address the risk for transmission of pathogens at venues where the public has contact with animals, some states have such laws (62,65,139–141). For example, after approximately 100 persons became ill after visiting a state fair petting zoo in 2004, North Carolina passed a law requiring agricultural fairs to obtain a permit from the North Carolina Department of Agriculture and Consumer Services for all animal exhibits open to the public (available at <http://www.ncleg.net/sessions/2005/bills/senate/html/S268v4.html>).

Certain federal agencies and associations in the United States have developed standards, recommendations, and guidelines for venues where animals are present in public settings. The Association of Zoos and Aquariums has accreditation standards for reducing risk for animal contact with the public in zoologic parks (142). In accordance with the Animal Welfare Act, USDA licenses and inspects certain animal exhibits for humane treatment of animals; however, the act does not address human health protection. In 2001, CDC issued guidelines to reduce the risk for infection with enteric pathogens associated with

farm visits (64). CDC also has issued recommendations for preventing transmission of *Salmonella* from reptiles and baby poultry to humans (74,143). The Association for Professionals in Infection Control and Epidemiology (APIC) and the Animal-Assisted Interventions Working Group (AAI) have developed guidelines to address risks associated with the use of animals in health-care settings (2,6). NASPHV has developed a compendium of measures to reduce risks of human exposure to *C. psittaci* (131).

## Recommendations for Local, State, and Federal Agencies

Communication and cooperation among human and animal health agencies should be enhanced and include veterinarians and cooperative extension offices. Additional research should be conducted regarding the risk factors and effective prevention and control methods for health issues associated with animal contact. To improve use of these recommendations, agencies should take the following steps:

- Disseminate this report to extension agents, venue operators, and others associated with managing animals in public settings. Most states do not have a complete list of animal contact venues (62). States should strive to develop a complete list to facilitate dissemination of recommendations.
- Disseminate educational and training materials to venue operators and other interested persons. Material formats could include PowerPoint slide presentations, videos, and written guidelines (129,130,144).
- Encourage or require oversight to ensure compliance with recommendations at animal contact venues.

To evaluate and improve these recommendations, surveillance for human health issues associated with animal contact should be enhanced. Agencies should take the following steps:

- Conduct thorough epidemiologic investigations of outbreaks.
- Include questions on disease report forms and outbreak investigation questionnaires about exposure to animals, animal environments, and animal products and feed.
- Follow appropriate protocols for sampling and testing of humans, animals, and the environment, including molecular subtyping of pathogen isolates.
- Report outbreaks to state health departments.
- Local and state public health departments should also report all outbreaks of enteric infections resulting from animal contact to CDC through the National Outbreak Reporting System (NORS) (available at <http://www.cdc.gov/enterics>).



## Recommendations for Education

Education is essential to reduce risks associated with animal contact in public settings. Experience from outbreaks suggests that visitors knowledgeable about potential risks are less likely to become ill (13). Even in well-designed venues with operators who are aware of the risks for disease, outbreaks can occur when visitors do not understand and apply disease-prevention recommendations.

Venue operators should take the following steps:

- Become knowledgeable about the risks for disease and injury associated with animals and be able to explain risk-reduction measures to staff members and visitors.
- Become familiar with and implement the recommendations in this compendium.
- Consult with veterinarians, state and local agencies, and county extension agents on implementation of the recommendations.
- Develop or obtain training and education materials and train staff members.
- Ensure that visitors receive educational messages before they enter the exhibit, including information that animals can cause injuries or carry organisms that can cause serious illness (Appendices A and B).
- Provide information in a simple and easy-to-understand format that is age- and language-appropriate.
- Provide information in multiple formats (e.g., signs, stickers, handouts, and verbal information).
- Provide information to persons arranging school field trips or classroom exhibits so that they can educate participants before the visit.

Venue staff members should take the following steps:

- Become knowledgeable about the risks for disease and injury associated with animals and be able to explain risk-reduction recommendations to visitors.
- Ensure that visitors receive educational messages regarding risks and preventive measures.
- Encourage compliance by the public with risk-reduction recommendations, especially compliance with hand-washing procedures (Appendix C) as visitors exit animal areas.
- Comply with local and state requirements for reporting animal bites or other injuries.

## Recommendations for Managing Public-Animal Contact

The recommendations in this report were developed for settings in which direct animal contact is encouraged (e.g., petting zoos and aquatic touch tanks) and in which animal contact is possible (e.g., county fairs). They should be tai-

lored to specific settings and incorporated into guidelines and regulations developed at the state or local level. Contact with animals should occur in settings where measures are in place to reduce the potential for injuries or disease transmission. Incidents or problems should be responded to, documented, and reported.

## Facility Design

The design of facilities and animal pens should minimize the risk associated with animal contact (Figure), including limiting direct contact with manure and encouraging hand washing (Appendix C). The design of facilities or contact settings might include double barriers to prevent contact with animals or contaminated surfaces except for specified animal interaction areas. Previous outbreaks have revealed that temporary exhibits are often not designed appropriately. Common problems include inadequate barriers, floor surfaces that are difficult to keep clean, insufficient plumbing, lack of signs regarding risk

**FIGURE.** Examples of designs for animal contact settings, including clearly designated animal areas, nonanimal areas, and transition areas with hand-washing stations and signs

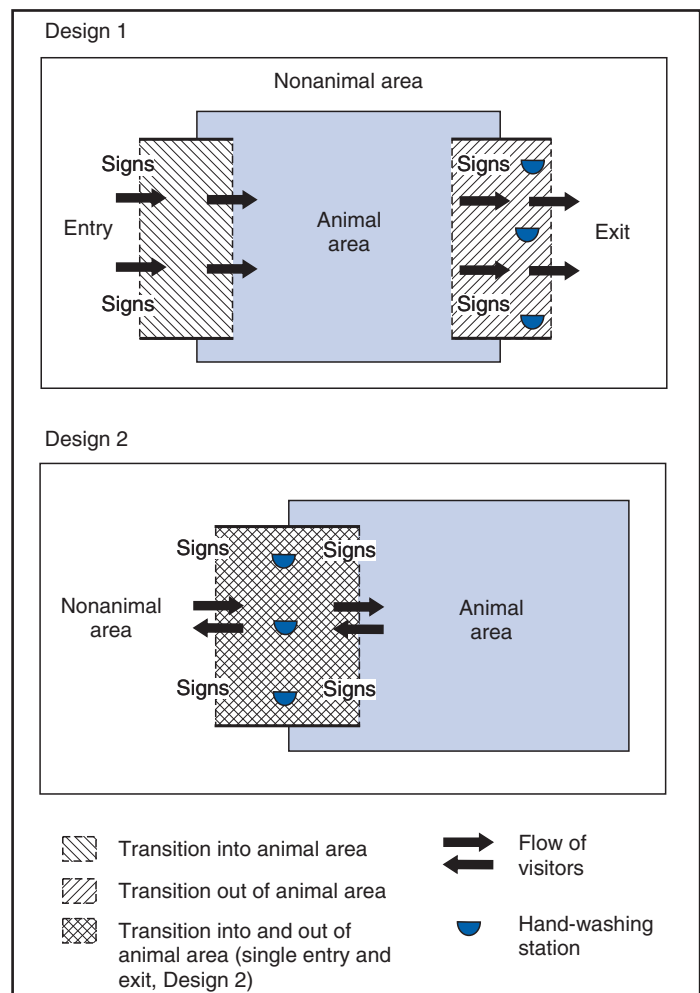

and prevention measures, and inadequate hand-washing facilities (13,18,31,34). Specific guidelines might be necessary for certain settings, such as schools (Appendix D).

Recommendations for cleaning procedures should be tailored to the specific situation. All surfaces should be cleaned thoroughly to remove organic matter before disinfection. A 1:32 dilution of household bleach (e.g., one-half cup bleach per gallon of water) is needed for basic disinfection. Quaternary ammonium compounds (e.g., Roccal or Zephiran) also can be used per the manufacturer label. For disinfection when a particular organism has been identified, additional guidance is available (<http://www.cfsph.iastate.edu/disinfection>). All compounds require >10 minutes of contact time with a contaminated surface.

Venues should be divided into three types of areas: nonanimal areas (areas in which animals are not permitted, with the exception of service animals), transition areas (located at entrances and exits to animal areas), and animal areas (where animal contact is possible or encouraged) (Figure).

### Nonanimal Areas

- Do not permit animals, except service animals, in nonanimal areas.
- Prepare, serve, and consume food and beverages only in nonanimal areas.
- Provide hand-washing facilities and display hand-washing signs where food or beverages are served (Appendix C).

### Transition Areas Between Nonanimal and Animal Areas

Establishing transition areas through which visitors pass when entering and exiting animal areas is critical. A one-way flow of visitors is preferred, with separate entrance and exit points. The transition areas should be designated as clearly as possible, even if they are conceptual rather than physical (Figure).

Entrance transition areas should be designed to facilitate education:

- Post signs or otherwise notify visitors that they are entering an animal area and that risks are associated with animal contact (Appendix B).
- Instruct visitors not to eat, drink, smoke, place their hands in their mouth, or use bottles or pacifiers while in the animal area.
- Do not allow strollers and related items (e.g., wagons and diaper bags) in areas where direct animal contact is encouraged. Establish storage or holding areas for these items.
- Control visitor traffic to prevent overcrowding.
- Exit transition areas should be designed to facilitate hand washing.

- Post signs or otherwise instruct visitors to wash their hands when leaving the animal area.
- Provide accessible hand-washing stations for all visitors, including children and persons with disabilities (Figure).
- Position venue staff members near exits to encourage compliance with hand washing.

### Animal Areas

- Do not allow food and beverages in animal areas.
- Do not allow toys, pacifiers, spill-proof cups, baby bottles, or strollers in animal areas.
- Prohibit smoking in animal areas.
- Supervise children closely to discourage hand-to-mouth activities (e.g., nail-biting and thumb-sucking), contact with manure, and contact with soiled bedding. Children should not be allowed to sit or play on the ground in animal areas. If hands become soiled, supervise hand washing.
- Ensure that animal feed and water are not accessible to the public.
- Allow feeding only when contact with animals is controlled (e.g., with barriers).
- Do not provide animal feed in containers that can be eaten by humans (e.g., ice cream cones) to decrease the risk for children eating food that has come into contact with animals.
- Assign trained staff members to encourage appropriate human-animal interactions, to identify and remove potential risks for patrons (e.g., by promptly cleaning up wastes), and process reports of injuries and exposures.
- Promptly remove manure and soiled animal bedding from animal areas.
- Store animal waste and specific tools for waste removal (e.g., shovels and pitchforks) in designated areas that are restricted from public access.
- Avoid transporting manure and soiled bedding through nonanimal areas or transition areas. If this is unavoidable, take precautions to prevent spillage.
- Where feasible, disinfect animal areas (e.g., flooring and railings) at least once daily.
- Provide adequate ventilation both for animals (145) and humans.
- Minimize the use of animal areas for public (nonanimal) activities. Zoonotic pathogens can contaminate the environment for substantial periods (37). If animal areas must be used for public events (e.g., weddings and dances), the areas should be cleaned and disinfected, particularly if food and beverages are served. Materials with smooth, impervious surfaces (e.g., steel, plastic, and sealed concrete) are easier to clean than other materials (e.g., wood or dirt

floors). Remove organic material (e.g., bedding, feed, and manure) before using disinfectants.

- For birds in bird encounter exhibits, refer to the psittacosis compendium (131) for recommendations regarding disease screening.
- Visitors to aquatic touch tank exhibits who have open wounds should be advised not to participate. Hand washing stations should be provided.
- When using animals or animal products (e.g., animal pelts, animal waste, and owl pellets) (69) for educational purposes, only use them in designated animal areas (Figure). Animals and animal products should not be brought into school cafeterias and other food-consumption areas.
- When animals are in school classrooms, specific areas must be designated for animal contact (Appendix D). Designated animal areas must be thoroughly cleaned after use. Parents should be informed of the benefits and potential risks associated with animals in school classrooms.

## Animal Care and Management

The risk for disease or injury from animal contact can be reduced by carefully managing the specific animals used. The following recommendations should be considered for management of animals in contact with the public.

- **Animal care:** Monitor animals daily for signs of illness, and ensure that animals receive appropriate veterinary care. Ill animals, animals known to be infected with a pathogen, and animals from herds with a recent history of abortion or diarrhea should not be exhibited. To decrease shedding of pathogens, animals should be housed to minimize stress and overcrowding.
- **Veterinary care:** Retain and use the services of a licensed veterinarian. Preventive care, including vaccination and parasite control, appropriate for the species should be provided. Certificates of veterinary inspection from an accredited veterinarian should be up-to-date according to local or state requirements for animals in public settings. A herd or flock inspection is a critical component of the health certificate process. Routine screening for diseases is not recommended, except for *C. psittaci* in bird encounter exhibits (131), tuberculosis in elephants (128) and primates, and Q fever in ruminants in birthing exhibits (146).
- **Rabies:** All animals should be housed to reduce potential exposure to wild animal rabies reservoirs. Mammals should also be up-to-date on rabies vaccinations (147). These steps are particularly critical in areas where rabies is endemic and in venues where animal contact is encouraged (e.g., petting zoos). Because of the extended incubation period

for rabies, unvaccinated mammals should be vaccinated at least 1 month before they have contact with the public. If no licensed rabies vaccine exists for a particular species (e.g., goats, swine, llamas, and camels) that is used in a setting where public contact occurs, consultation with a veterinarian regarding off-label use of rabies vaccine is recommended. Use of off-label vaccine does not provide the same level of assurance as vaccine labeled for use in a particular species; however, off-label use of vaccine might provide protection for certain animals and thus decrease the probability of rabies transmission (147). Vaccinating slaughter-class animals before displaying them at fairs might not be feasible because of the vaccine withdrawal period that occurs as a result of antibiotics used as preservatives in certain vaccines. Mammals that are too young to be vaccinated should be used in exhibit settings only if additional restrictive measures are available to reduce risks (e.g., using only animals that were born to vaccinated mothers and housed to avoid rabies exposure). In animal contact settings, rabies testing should be considered for animals that die suddenly.

- **Dangerous animals:** Because of their strength, unpredictability, or venom or the pathogens that they might carry, certain domestic, exotic, or wild animals should be prohibited in exhibit settings where a reasonable possibility of animal contact exists. Species of primary concern include nonhuman primates (e.g., monkeys and apes) and certain carnivores (e.g., lions, tigers, ocelots, wolves and wolf hybrids, and bears). In addition, rabies-reservoir species (e.g., bats, raccoons, skunks, foxes, and coyotes) should not be used for direct contact.
- **Animal births:** Ensure that the public has no contact with animal birthing by-products (e.g., the placenta). In live-birth exhibits, the environment should be thoroughly cleaned after each birth, and all waste products should be properly discarded. Holding such events outside or in well-ventilated areas is preferable.

## Additional Recommendations

- **Populations at high risk:** Children aged <5 years are at particularly high risk for serious infections. Other groups at increased risk include persons with waning immunity (e.g., older adults) and persons who are mentally impaired, pregnant, or immunocompromised (e.g., persons with human immunodeficiency virus/acquired immunodeficiency syndrome, without a functioning spleen, or receiving immunosuppressive therapy). Persons at high risk for infection should take precautions at any animal exhibit. In addition to thorough and frequent hand washing, height-



ened precautions could include avoiding contact with animals and their environment (e.g., pens, bedding, and manure). Animals of particular concern for transmitting enteric diseases include young ruminants, young poultry, reptiles, amphibians, and ill animals.

- **Consumption of unpasteurized products:** Prohibit the consumption of unpasteurized dairy products (e.g., milk, cheese, and yogurt) and unpasteurized apple cider or juices.
- **Drinking water:** Local public health authorities should inspect drinking water systems before use. Only potable water should be used for consumption by animals and humans. Back-flow prevention devices should be installed between outlets in livestock areas and water lines supplying other areas on the grounds. If the water supply is from a well, adequate distance should be maintained from possible sources of contamination (e.g., animal-holding areas and manure piles). Maps of the water distribution system should be available for use in identifying potential or actual problems. The use of outdoor hoses should be minimized, and hoses should not be left on the ground. Hoses that are accessible to the public should be labeled “water not for human consumption.” Operators and managers of settings in which treated municipal water is not available should ensure that a safe water supply is available.

## References

1. Steinmuller N, Demma L, Bender JB, Eidson M, Angulo FJ. Outbreaks of enteric disease associated with animal contact: not just a foodborne problem anymore. *Clin Infect Dis* 2006;43:1596–602.
2. Duncan SL. APIC State-of-the-art report: the implications of service animals in health care settings. *Am J Infect Control* 2000;28:170–80.
3. Sehulster L, Chinn R, Arduino M, et al. Guidelines for environmental infection control in health-care facilities: recommendations of CDC and the Healthcare Infection Control Practices Advisory Committee (HICPAC). Chicago, IL: American Society for Healthcare Engineering/American Hospital Association, 2004. Available at [http://www.cdc.gov/ncidod/dhqp/pdf/guidelines/enviro\\_guide\\_03.pdf](http://www.cdc.gov/ncidod/dhqp/pdf/guidelines/enviro_guide_03.pdf).
4. Guay DR. Pet-assisted therapy in the nursing home setting: potential for zoonosis. *Am J Infect Control* 2001;29:178–86.
5. National Association of State Public Health Veterinarians. Compendium of veterinary standard precautions, zoonotic disease prevention in veterinary personnel, 2006. Available at <http://www.nasphv.org/Documents/VeterinaryPrecautions.pdf>.
6. Lefebvre SL, Golab GC, Christensen E, et al. Guidelines for animal-assisted interventions in health care facilities. *Am J Infect Control* 2008;36:78–85.
7. LeJeune JT, Davis MA. Outbreaks of zoonotic enteric disease associated with animal exhibits. *J Am Vet Med Assoc* 2004;224:1440–5.
8. Chappell CL, Okhuysen PC, Sterling CR, DuPont HL. *Cryptosporidium parvum*: intensity of infection and oocyst excretion patterns in healthy volunteers. *J Infect Dis* 1996;173:232–6.
9. Bell BP, Goldoft M, Griffin PM, et al. A multistate outbreak of *Escherichia coli* O157:H7-associated bloody diarrhea and hemolytic uremic syndrome from hamburgers: the Washington experience. *JAMA* 1994;272:1349–53.
10. Tilden J, Jr., Young W, McNamara AM, et al. A new route of transmission for *Escherichia coli*: infection from dry fermented salami. *Am J Public Health* 1996;86:1142–5.
11. Shukla R, Slack R, George A, Cheasty T, Rowe B, Scutter J. *Escherichia coli* O157 infection associated with a farm visitor centre. *Commun Dis Rep CDR Rev* 1995;5:R86–90.
12. Sayers G, Dillon M, Connolly E, et al. Cryptosporidiosis in children who visited an open farm. *Commun Dis Rep CDR Rev* 1996;6:R140–4.
13. CDC. Outbreaks of *Escherichia coli* O157:H7 associated with petting zoos—North Carolina, Florida, and Arizona, 2004 and 2005. *MMWR* 2005;54:1277–80.
14. Crump JA, Sulka AC, Langer AJ, et al. An outbreak of *Escherichia coli* O157:H7 infections among visitors to a dairy farm. *N Engl J Med* 2002;347:555–60.
15. David ST, MacDougall L, Louie K, et al. Petting zoo-associated *Escherichia coli* O157:H7—secondary transmission, asymptomatic infection, and prolonged shedding in the classroom. *Can Commun Dis Rep* 2004;30:173–80.
16. Durso LM, Reynolds K, Bauer N Jr., Keen JE. Shiga-toxigenic *Escherichia coli* O157:H7 infections among livestock exhibitors and visitors at a Texas county fair. *Vector Borne Zoonotic Dis* 2005;5:193–201.
17. Evans M, Gardner D. Cryptosporidiosis outbreak associated with an educational farm holiday. *Commun Dis Rep CDR Rev* 1996;1996:R50–1.
18. Friedman CR, Torigian C, Shillam PJ, et al. An outbreak of salmonellosis among children attending a reptile exhibit at a zoo. *J Pediatr* 1998;132:802–7.
19. Kiang KM, Scheftel JM, Leano FT, et al. Recurrent outbreaks of cryptosporidiosis associated with calves among students at an educational farm program, Minnesota, 2003. *Epidemiol Infect* 2006;134:878–86.
20. Pritchard GC, Willshaw GA, Bailey JR, Carson T, Cheasty T. Verocytotoxin-producing *Escherichia coli* O157 on a farm open to the public: outbreak investigation and longitudinal bacteriological study. *Vet Rec* 2000;147:259–64.
21. Smith KE, Stenzel SA, Bender JB, et al. Outbreaks of enteric infections caused by multiple pathogens associated with calves at a farm day camp. *Pediatr Infect Dis J* 2004;23:1098–104.
22. Warshawsky B, Gutmanis I, Henry B, et al. An outbreak of *Escherichia coli* O157:H7 related to animal contact at a petting zoo. *Can J Infect Dis* 2002;13:175–81.
23. Chapman PA, Cornell J, Green C. Infection with verocytotoxin-producing *Escherichia coli* O157 during a visit to an inner city open farm. *Epidemiol Infect* 2000;125:531–6.
24. CDC. Three outbreaks of salmonellosis associated with baby poultry from three hatcheries—United States, 2006. *MMWR* 2007;56:273–6.
25. Fuller CC, Jawahir SL, Leano FT, et al. A multi-state *Salmonella* Typhimurium outbreak associated with frozen vacuum-packed rodents used to feed snakes. *Zoonoses Public Health*. 2008;55:481–7.
26. Keen JE, Elder RO. Isolation of Shiga-toxigenic *Escherichia coli* O157 from hide surfaces and the oral cavity of finished beef feedlot cattle. *J Am Vet Med Assoc* 2002;220:756–63.

27. Keene W, deBroekert M, Gillette K. A large *Escherichia coli* O157:H7 outbreak at a county fair [Abstract 55:77]. In: Programs and abstracts of the International Conference on Emerging Infectious Diseases, Atlanta, GA; February 29–March 3, 2004.
28. Croft DR, Archer J, Roberts C, et al. Outbreak of *Escherichia coli* O157:H7 infections associated with a pancake breakfast served in a stock pavilion with contaminated livestock bedding—Wisconsin, 2001. In: Programs and abstracts of the 51st Annual Epidemic Intelligence Conference, Atlanta, GA; April 22–26, 2002.
29. Doorduyn Y, Van Den Brandhof WE, Van Duynhoven YT, Wannet WJ, Van Pelt W. Risk factors for *Salmonella* Enteritidis and Typhimurium (DT104 and non-DT104) infections in The Netherlands: predominant roles for raw eggs in Enteritidis and sandboxes in Typhimurium infections. *Epidemiol Infect* 2006;134:617–26.
30. Varma JK, Greene KD, Reller ME, et al. An outbreak of *Escherichia coli* O157 infection following exposure to a contaminated building. *JAMA* 2003;290:2709–12.
31. Payne CJ, Petrovic M, Roberts RJ, et al. Vero cytotoxin-producing *Escherichia coli* O157 gastroenteritis in farm visitors, North Wales. *Emerg Infect Dis* 2003;9:526–30.
32. Djuretic T, Wall PG, Nichols G. General outbreaks of infectious intestinal disease associated with milk and dairy products in England and Wales: 1992 to 1996. *Commun Dis Rep CDR Rev* 1997;7:R41–5.
33. Korlath JA, Osterholm MT, Judy LA, Forfang JC, Robinson RA. A point-source outbreak of campylobacteriosis associated with consumption of raw milk. *J Infect Dis* 1985;152:592–6.
34. Sharp JC. Infections associated with milk and dairy products in Europe and North America, 1980–85. *Bull World Health Organ* 1987;65:397–406.
35. DeSchrijver K, Buvens G, Possé B, et al. Outbreak of verocytotoxin-producing *E. coli* 145 and O26 infections associated with the consumption of ice cream produced at a farm, Belgium, 2007. *Eurosurveillance* 2008;13:1–2.
36. Anonymous. Waterborne outbreak of gastroenteritis associated with a contaminated municipal water supply, Walkerton, Ontario, May–June 2000. *Can Commun Dis Rep* 2000;26:170–3.
37. Bopp DJ, Saunders BD, Waring AL, et al. Detection, isolation, and molecular subtyping of *Escherichia coli* O157:H7 and *Campylobacter jejuni* associated with a large waterborne outbreak. *J Clin Microbiol* 2003;41:174–80.
38. CDC. Outbreak of *Escherichia coli* O157:H7 and *Campylobacter* among attendees of the Washington County Fair—New York, 1999. *MMWR* 1999;48:803–5.
39. Keen JE, Wittum TE, Dunn JR, Bono JL, Durso LM. Shiga-toxicogenic *Escherichia coli* O157 in agricultural fair livestock, United States. *Emerg Infect Dis* 2006;12:780–6.
40. Kudva IT, Blanch K, Hovde CJ. Analysis of *Escherichia coli* O157:H7 survival in ovine or bovine manure and manure slurry. *Appl Environ Microbiol* 1998;64:3166–74.
41. LeJeune JT, Besser TE, Hancock DD. Cattle water troughs as reservoirs of *Escherichia coli* O157. *Appl Environ Microbiol* 2001;67:3053–7.
42. Maule A. Survival of verocytotoxigenic *Escherichia coli* O157 in soil, water, and on surfaces. *J Appl Microbiol* 2000;29:S71–8.
43. Rahn K, Renwick SA, Johnson RP, et al. Persistence of *Escherichia coli* O157:H7 in dairy cattle and the dairy farm environment. *Epidemiol Infect* 1997;119:251–9.
44. Randall LP, Wray C, Davies RH. Survival of verocytotoxin-producing *Escherichia coli* O157 under simulated farm conditions. *Vet Rec* 1999;145:500–1.
45. Béraud R, Huneault L, Bernier D, et al. Comparison of the selection of antimicrobial resistance in fecal *Escherichia coli* during enrofloxacin administration with a local drug delivery system or with intramuscular injections in a swine model. *Can. J. Vet Res* 2008;72:311–9.
46. Corrier DE, Purdy CW, DeLoach JR. Effects of marketing stress on fecal excretion of *Salmonella* spp in feeder calves. *Am J Vet Res* 1990;51:866–9.
47. Hurd HS, McKean JD, Griffith RW, Wesley IV, Rostagno MH. *Salmonella enterica* infections in market swine with and without transport and holding. *Appl Environ Microbiol* 2002;68:2376–81.
48. Hurd HS, McKean JD, Wesley IV, Karriker LA. The effect of lairage on *Salmonella* isolation from market swine. *J Food Prot* 2001;64:939–44.
49. Isaacson RE, Firkins LD, Weigel RM, Zuckermann FA, DiPietro JA. Effect of transportation and feed withdrawal on shedding of *Salmonella typhimurium* among experimentally infected pigs. *Am J Vet Res* 1999;60:1155–8.
50. Marg H, Scholz HC, Arnold T, Rosler U, Hensel A. Influence of long-time transportation stress on re-activation of *Salmonella typhimurium* DT104 in experimentally infected pigs. *Berl Munch Tierarztl Wochenschr* 2001;114:385–8.
51. US Department of Agriculture. *Escherichia coli* O157 in the United States feedlots. Fort Collins, CO: US Department of Agriculture, Centers for Epidemiology and Animal Health, Animal and Plant Health Inspection Service, Veterinary Services; 2001. Available at <http://nahms.aphis.usda.gov/feedlot/feedlot99/FD99ecoli.pdf>.
52. Williams LP, Newell KW. *Salmonella* excretion in joy-riding pigs. *Am J Public Health Nations Health* 1970;60:926–9.
53. Webb CR. Investigating the potential spread of infectious diseases of sheep via agricultural shows in Great Britain. *Epidemiol Infect* 2006;134:31–40.
54. Garber LP, Wells SJ, Hancock DD, et al. Risk factors for fecal shedding of *Escherichia coli* O157:H7 in dairy calves. *J Am Vet Med Assoc* 1995;207:46–9.
55. Hancock DD, Besser TE, Kinsel ML, Tarr PI, Rice DH, Paros MG. The prevalence of *Escherichia coli* O157:H7 in dairy and beef cattle in Washington state. *Epidemiol Infect* 1994;113:199–207.
56. Hancock DD, Besser TE, Rice DH, Herriott DE, Tarr PI. A longitudinal study of *Escherichia coli* O157 in fourteen cattle herds. *Epidemiol Infect* 1997;118:193–5.
57. US Department of Agriculture. *Salmonella* in United States feedlots. Fort Collins, CO: US Department of Agriculture, Centers for Epidemiology and Animal Health, Animal and Plant Health Inspection Service, Veterinary Services; 2001. Available at <http://nahms.aphis.usda.gov/feedlot/feedlot99/FD99ecoli.pdf>.
58. McMillian M, Dunn JR, Keen JE, Brady KL, Jones TF. Risk behaviors for disease transmission among petting zoo attendees. *JAVMA* 2007;231:1036–8.
59. Soderlund D, Smith K, Bender J, Hedberg C. An epidemiologic investigation of cryptosporidiosis in Minnesota. In: Programs and abstracts of the International Conference on Emerging Infectious Diseases, Atlanta, GA; July 16–19, 2000.
60. Belongia EA, Chyou PH, Greenlee RT, Perez-Perez G, Bibb WF, DeVries EO. Diarrhea incidence and farm-related risk factors for *Escherichia coli* O157:H7 and *Campylobacter jejuni* antibodies among rural children. *J Infect Dis* 2003;187:1460–8.

61. Keen JE, Durso LM, Meehan TP. Isolation of *Salmonella enterica* and Shiga-toxigenic *Escherichia coli* O157 from feces of animals in public contact areas of United States zoological parks. *Appl Environ Microbiol* 2007;73:362–5.
62. Bender JB, Shulman SA. Reports of zoonotic disease outbreaks associated with animal exhibits and availability of recommendations for preventing zoonotic disease transmission from animals to people in such settings. *J Am Vet Med Assoc* 2004;224:1105–9.
63. Crump JA, Braden CR, Dey ME, et al. Outbreaks of *Escherichia coli* O157 infections at multiple county agricultural fairs: a hazard of mixing cattle, concession stands and children. *Epidemiol Infect* 2003;131:1055–62.
64. CDC. Outbreaks of *Escherichia coli* O157:H7 infections among children associated with farm visits—Pennsylvania and Washington, 2000. *MMWR* 2001;50:293–7.
65. Chertow D. Outbreak of *Escherichia coli* O157:H7 related to direct and indirect animal contact in petting zoos—Florida, 2005. In: Programs and abstracts of the 55th Annual Epidemic Intelligence Service Conference, Atlanta, GA; April 24–28, 2006.
66. North Carolina Department of Health and Human Services. *E. coli* outbreak. Raleigh, NC: North Carolina Department of Health and Human Services; 2004. Available at <http://www.epi.state.nc.us/epi/gedc/ecoli/EColiReportFinal062905.pdf>.
67. Durso LM, Keen JE, Bauer N Jr. Assessment of three remediation strategies for reduction of Shiga-toxinogenic *Escherichia coli* (STEC) O157 in naturally contaminated soil. In: Abstracts of the Institute of Food Technology Annual Meeting & Food Expo, Chicago, IL; July 26–30, 2007.
68. Coronado F, Johnson G, Kacica M, et al. A large outbreak of cryptosporidiosis and *Escherichia coli* O111 infections associated with consumption of unpasteurized apple cider—New York, 2004. In: Programs and abstracts of the 54th Annual Epidemic Intelligence Service Conference, Atlanta, GA; April 11–15, 2005.
69. Smith KE, Anderson F, Medus C, Leano F, Adams J. Outbreaks of salmonellosis at elementary schools associated with dissection of owl pellets. *Vector Borne Zoonotic Dis* 2005;5:133–6.
70. Lamm SH, Taylor A, Gangarosa EJ, et al. Turtle-associated salmonellosis. *Am J Epidemiol* 1972;95:511–7.
71. Swanson SJ, Snider C, Braden CR, et al. Multidrug-resistant *Salmonella enterica* serotype Typhimurium associated with pet rodents. *N Engl J Med* 2007;356:21–8.
72. CDC. *Salmonella hadar* associated with pet ducklings—Connecticut, Maryland, and Pennsylvania, 1991. *MMWR* 1992;41:185–7.
73. CDC. *Salmonella* serotype Montevideo infections associated with chicks—Idaho, Washington, and Oregon, spring 1995 and 1996. *MMWR* 1997;46:237–9.
74. CDC. Salmonellosis associated with chicks and ducklings—Michigan and Missouri, spring 1999. *MMWR* 2000;49:297–9.
75. CDC. Multistate outbreaks of *Salmonella* infections associated with live poultry—United States, 2007. *MMWR* 2009;58:25–9.
76. CDC. Turtle-associated salmonellosis in humans—United States, 2006–2007. *MMWR* 2007;56:649–52.
77. CDC. Multistate outbreak of human *Salmonella* infections associated with exposure to turtles—United States, 2007–2008. *MMWR* 2008;57:69–72.
78. CDC. Multistate outbreak of human *Salmonella* infections caused by contaminated dry dog food—United States, 2006–2007. *MMWR* 2008;57:521–4.
79. CDC. Update: recall of dry dog and cat food products associated with human *Salmonella* infections—United States, 2008. *MMWR* 2008;57:1200–2.
80. Laboratory Centre for Disease Control, Public Health Agency of Canada. Human health risk from exposure to natural dog treats. *Can Commun Dis Rep* 2000;26:41–2.
81. Clark C, Cunningham J, Ahmed R, et al. Characterization of *Salmonella* associated with pig ear dog treats in Canada. *J Clin Microbiol* 2001;39:3962–8.
82. Pitout JD, Reisbig MD, Mulvey M, et al. Association between handling of pet treats and infection with *Salmonella enterica* serotype Newport expressing the AmpC  $\beta$ -lactamase, CMY-2. *J Clin Microbiol* 2003;41:4578–82.
83. CDC. Human salmonellosis associated with animal-derived pet treats—United States and Canada, 2005. *MMWR* 2006;55:702–5.
84. Levings RS, Lightfoot D, Hall RM, Djordjevic SP. Aquariums as reservoirs for multidrug-resistant *Salmonella* Paratyphi B. *Emerg Infect Dis* 2005;12:507–10.
85. Musto J, Kirk M, Lightfoot D, et al. Multi-drug resistant *Salmonella* Java infections acquired from tropical fish aquariums, Australia, 2003–04. *CDI* 2006;30:222–7.
86. CDC. Epidemiologic notes and reports aquarium-associated *Plesiomonas shigelloides* infection—Missouri. *MMWR* 1989;38:617–9.
87. Kassenborg HD, Hedberg CW, Hoekstra M, et al. Farm visits and undercooked hamburgers as major risk factors for sporadic *Escherichia coli* O157:H7 infection: data from a case-control study in 5 FoodNet sites. *Clin Infect Dis* 2004;38:S271–S8.
88. O'Brien SJ, Adak GK, Gilham C. Contact with farming environment as a major risk factor for Shiga toxin (Vero cytotoxin)-producing *Escherichia coli* O157 infection in humans. *Emerg Infect Dis* 2001;7:1049–51.
89. Haack JP, Jelacic S, Besser TE, et al. *Escherichia coli* O157 exposure in Wyoming and Seattle: serologic evidence of rural risk. *Emerg Infect Dis* 2003;9:1226–31.
90. Hunter PR, Hughes S, Woodhouse S, et al. Sporadic cryptosporidiosis case-control study with genotyping. *Emerg Infect Dis* 2004;10:1241–9.
91. Roy SL, DeLong SM, Stenzel SA, et al. Risk factors for sporadic cryptosporidiosis among immunocompetent persons in the United States from 1999 to 2001. *J Clin Microbiol* 2004;42:2944–51.
92. Friedman CR, Hoekstra RM, Samuel M, et al. Risk factors for sporadic *Campylobacter* infection in the United States: a case-control study in FoodNet sites. *Clin Infect Dis* 2004;38:S285–S96.
93. Bardana EJ Jr. What characterizes allergic asthma? *Ann Allergy* 1992;68:371–3.
94. American Academy of Allergy Asthma and Immunology. Executive summary report, 1998. Milwaukee, WI: Task Force on Allergic Disorders; 1998.
95. Lincoln TA, Bolton NE, Garrett AS, Jr. Occupational allergy to animal dander and sera. *J Occup Med* 1974;16:465–9.
96. Kelso JM, Fox RW, Jones RT, Yunginger JW. Allergy to iguana. *J Allergy Clin Immunol* 2000;106:369–72.
97. Levine EG, Manilov A, McAllister SC, Heymann WR. Iguana bite-induced hypersensitivity reaction. *Arch Dermatol* 2003;139:1658–9.
98. American Academy of Allergy Asthma and Immunology. Tips to remember: indoor allergens. Available at [www.aaaai.org/patients/publicedmat/tips/indoorallergens.stm](http://www.aaaai.org/patients/publicedmat/tips/indoorallergens.stm).
99. Fairley JA, Suchniak J, Paller AS. Hedgehog hives. *Arch Dermatol* 1999;135:561–3.



100. Siemaszko C. Tiger kills Kansas teen: mauled while posing for pic. *New York Daily News*. August 20, 2005.
101. CDC. Mass treatment of humans exposed to rabies—New Hampshire, 1994. *MMWR* 1995;44:484–6.
102. Chang HG, Eidson M, Noonan-Toly C, et al. Public health impact of reemergence of rabies, New York. *Emerg Infect Dis* 2002;8:909–13.
103. CDC. Public health response to a potentially rabid bear cub—Iowa, 1999. *MMWR* 1999;48:971–3.
104. CDC. Multiple human exposures to a rabid bear cub at a petting zoo and barnwarming—Iowa, August 1999. *MMWR* 1999;48:761.
105. Robbins A, Eidson M, Keegan M, Sackett D, Laniewicz B. Bat incidents at children's camps, New York State, 1998–2002. *Emerg Infect Dis* 2005;11:302–5.
106. CDC. Tularemia associated with a hamster bite—Colorado, 2004. *MMWR* 2005;53:1202–3.
107. CDC. Fatal *Cercopithecine herpesvirus* 1 (B virus) infection following a mucocutaneous exposure and interim recommendations for worker protection. *MMWR* 1998;47:1073–6,1083.
108. Cohen JI, Davenport DS, Stewart JA, Deitchman S, Hilliard JK, Chapman LE. Recommendations for prevention of and therapy for exposure to B virus (*Cercopithecine herpesvirus* 1). *Clin Infect Dis* 2002;35:1191–203.
109. Hullinger G, Cole JJ, Elvinger F, Stewart R. Dermatophytosis in show lambs in the United States. *Vet Dermatol* 1999;10:73–6.
110. Scott WA. Ringworm outbreak [letter]. *Vet Rec* 1986;118:342.
111. Lederman ER, Austin C, Trevino I, et al. ORF virus infection in children: clinical characteristics, transmission, diagnostic methods, and future therapeutics. *Pediatr Infect Dis J* 2007;740–4.
112. Stover J, Dolensek E, Basford B, Beheny J. Contagious ecthyma in a children's zoo. *J Zoo An Med* 1986;17:115–6.
113. Marennikova SS, Maltseva NN, Korneeva VI, Garanina N. Outbreak of pox disease among Carnivora (Felidae) and edentata. *J Infect Dis* 1977;135:358–66.
114. CDC. Update: Multistate outbreak of monkeypox—Illinois, Indiana, Kansas, Missouri, Ohio, and Wisconsin, 2003. *MMWR* 2003;52:642–6.
115. Kile JC, Fleishchauer AT, Kuehnert MJ, et al. Transmission of monkeypox among exposed daycare attendees: Indiana, 2003 [Abstract 51:132]. In: Programs and abstracts of the International Conference on Emerging Infectious Diseases, Atlanta, GA; February 29–March 3, 2004.
116. Nemetz TG, Shotts EB, Jr. Zoonotic diseases. In: Stoskopf MK. *Fish medicine*. Philadelphia, PA:WB Saunders; 1993. pp. 214–20.
117. Gray SE, Stanwell Smith R, Reynolds NJ, Williams EW. Fish tank granuloma. *BMJ*;300:1069–70.
118. Lewis FM, Marsh BJ, von Reyn CF. Fish tank exposure and cutaneous infections due to *Mycobacterium marinum*: tuberculin skin testing, treatment, and prevention. *Clin Infect Dis* 2003;37:390–7.
119. Angarano DW, Parish LC. Comparative dermatology: parasitic disorders. *Clin Dermatol* 1994;12:543–50.
120. Arlian LG. Biology, host relations, and epidemiology of *Sarcoptes scabiei*. *Annu Rev Entomol* 1989;34:139–61.
121. Scott DW, Horn RT, Jr. Zoonotic dermatoses of dogs and cats. *Vet Clin North Am Small Anim Pract* 1987;17:117–44.
122. Lucky AW, Sayers C, Argus JD, Lucky A. Avian mite bites acquired from a new source—pet gerbils. *Arch Dermatol* 2001;137:167–70.
123. Currier RW, 2nd, Kinzer GM, DeShields E. *Dipylidium caninum* infection in a 14-month-old child. *South Med J* 1973;66:1060–2.
124. Molina CP, Ogburn J, Adegboyega P. Infection by *Dipylidium caninum* in an infant. *Arch Pathol Lab Med* 2003;127:e157–9.
125. Schantz PM. Toxocara larva migrans now. *Am J Trop Med Hyg* 1989;41:21–34.
126. Michalak K, Austin C, Diesel S, Bacon MJ, Zimmerman P, Maslow JN. *Mycobacterium tuberculosis* infection as a zoonotic disease: transmission between humans and elephants. *Emerg Infect Dis* 1998;4:283–7.
127. Stetter MD, Mikota SK, Gutter AF, et al. Epizootic of *Mycobacterium bovis* in a zoologic park. *J Am Vet Med Assoc* 1995;207:1618–21.
128. US National Tuberculosis Working Group for Zoo and Wildlife Species. Guidelines for the control of tuberculosis in elephants, 2003. Riverdale, MD: US National Tuberculosis Working Group for Zoo and Wildlife Species; 2003. Available at [http://www.aphis.usda.gov/animal\\_welfare/downloads/elephant/tb2003.pdf](http://www.aphis.usda.gov/animal_welfare/downloads/elephant/tb2003.pdf).
129. Heymann D. Control of communicable diseases manual. 18th ed. Washington DC: American Public Health Association; 2004.
130. Milford F, Vibien A, Lambert L, Morin M, Petit G, Trottier J. Large Q-fever outbreak related to exposure to petting zoos in two shopping malls. In: Programs and abstracts of the 51st Annual Conference on Diseases in Nature Transmissible to Man; Austin, Texas; June 2001.
131. Smith KA, Campbell, CT, Murphy J, Stobierski MG, Tengelsen LA. Compendium of measures to control *Chlamydothyla psittaci* infection among humans (psittacosis) and pet birds (avian chlamydiosis), 2009. Available at <http://www.nasphv.org/Documents/Psittacosis.pdf>.
132. Christensen A, Jarlov J, Ingeberg S. The risk of ornithosis among the staff of Copenhagen Zoo. *Ugeskr Laeger* 1990;152:818–20.
133. Eidson M. Psittacosis/avian chlamydiosis. *J Am Vet Med Assoc* 2002;221:1710–2.
134. Hyde SR, Benirschke K. Gestational psittacosis: case report and literature review. *Mod Pathol* 1997;10:602–7.
135. Ohio Department of Health Zoonotic Disease Program. Human and swine influenza (H1N1) outbreak in Huron County, Ohio—August 2007; 2008. Ohio Disease Reporting System report nos. 886011 and 886013.
136. Casemore D. Educational farm visits and associated infection hazards. *Commun Dis Rep CDR Rev* 1989;19:R3.
137. Dawson A, Griffin R, Fleetwood A, Barrett NJ. Farm visits and zoonoses. *Commun Dis Rep CDR Rev* 1995; 5:R81–6.
138. Warshawsky B, Henry B, Gutmanis I, et al. An *E. coli* O157:H7 outbreak associated with an animal exhibit: Middlesex-London Health Unit investigation and recommendations—executive summary. Vol. 2006. Middlesex, London; Ontario, Canada: Middlesex-London Health Unit; 1999.
139. Washington State Department of Health. Recommendations to reduce the risk of disease transmission from animals to humans at petting zoos, fairs and other animal exhibits. Olympia, WA: Washington State Department of Health, Office of Environmental Health and Safety, 2001. Available at <http://kitsap.wsu.edu/4h/fair/recommendationspettingzoo.pdf>.
140. Animal Exhibition Sanitation Act 211 of 2002. Pennsylvania Bureau of Animal Health and Diagnostic Services. May 6, 2002. Available at <http://www.agriculture.state.pa.us/agriculture/lib/agriculture/legalreference/act211of2002.pdf>.
141. Commonwealth of Massachusetts Department of Public Health. Recommendations for petting zoos, petting farms, animal fairs, and other events and exhibits where contact between animals and people is permitted. Boston, MA: Commonwealth of Massachusetts Department of Public Health, Bureau of Communicable Disease Control; 2004. Available at [http://www.mass.gov/Eeoehhs2/docs/dph/cdc/rabies/reduce\\_zoos\\_risk.pdf](http://www.mass.gov/Eeoehhs2/docs/dph/cdc/rabies/reduce_zoos_risk.pdf).

142. Association of Zoos and Aquariums. The accreditation standards and related policies. 2009 edition. Silver Spring, MD: Association of Zoos and Aquariums; 2009. Available at <http://www.aza.org/accreditation/documents/accredstandpol.pdf>.
143. CDC. Reptile-associated salmonellosis—selected states, 1998–2002. *MMWR* 2003;52:1206–9.
144. CDC. Healthy pets healthy people. Atlanta, GA: US Department of Health and Human Services, CDC; 2004. Available at <http://www.cdc.gov/healthypets>.
145. Midwest Plan Service. Heating, cooling and tempering air for livestock housing. Ames, IA: Iowa State University; 1990.
146. Ross C, Morrow PS. Q fever: an issue in occupational health & safety? An overview of the methods of control and the effects of *Coxiella burnetii* on the human host. *J R Soc Health* 1994;114:151–2.
147. National Association of State Public Health Veterinarians. Compendium of animal rabies prevention and control, 2008. Available at <http://www.nasphv.org/Documents/RabiesCompendium.pdf>.

---

### **National Association of State Public Health Veterinarians, Inc., Committee**

**Co-chairpersons:** Carina Blackmore, DVM, PhD, Florida Department of Health, Tallahassee, Florida; John R. Dunn, DVM, PhD, Tennessee Department of Health, Nashville, Tennessee.

**Members:** Kirk E. Smith, DVM, PhD, Minnesota Department of Health, St. Paul, Minnesota; James H. Wright, DVM, Texas Department of State Health Services, Tyler, Texas; Ron Wohrle, DVM, Washington State Department of Health, Olympia, Washington; Louisa Castrodale, DVM, Alaska Department of Health and Social Services, Anchorage, Alaska.

**Consultants to the Committee:** Casey Barton Behravesh, DVM, DrPH, CDC, Atlanta, Georgia; Sue K. Billings, DVM, National Assembly of State Animal Health Officials, Washington, DC; Marianne Ash, DVM, American Veterinary Medical Association Council on Public Health and Regulatory Veterinary Medicine, Schaumburg, Illinois; Marla J. Calico, International Association of Fairs and Expositions, Springfield, Missouri; Allan Hogue, DVM, US Department of Agriculture, Riverdale, Maryland; Timothy F. Jones, MD, Council of State and Territorial Epidemiologists, Atlanta, Georgia; Thomas P. Meehan, DVM, Association of Zoos and Aquariums, Silver Spring, Maryland.

---



## Appendix A

### Animals in Public Settings: Guidelines for Venue Operators and Staff Members

Venue operators should know about risks for disease and injury, maintain a safe environment, and inform staff members and visitors about appropriate disease- and injury-prevention measures. This handout provides basic information and instructions for venue operators and staff. Consultation with veterinarians, public health officials, or other professionals to fully implement the recommendations in this report is suggested.

#### **Operators and staff members should be aware of the following risks for disease and injury associated with animals in public settings:**

- Disease and injuries have occurred following contact with animals in public settings.
- Healthy animals can carry germs that make visitors sick.
- Visitors can pick up germs when they touch animals or animal droppings or enter an animal's environment.
- Visitors can rid themselves of most germs if they wash their hands when leaving a public setting with animals and should do so even if they did not directly contact the animals.
- The risk for developing serious or life-threatening illnesses from contact with animals in public settings is higher among certain visitors, especially young children (i.e., aged <5 years), older adults, pregnant women, and persons with weakened immune systems.

#### **Operators and staff members should take the following steps to maintain a safe environment when animals are present in public settings:**

- Design the venue with safety in mind by having designated animal areas, nonanimal areas, and transition areas.
- Do not permit any animals other than service animals in nonanimal areas.
- Provide hand-washing facilities where food and beverages are prepared, served, or consumed.
- Assign trained staff members to monitor animal contact areas.
- Exclude food and beverages, toys, pacifiers, spill-proof cups, and baby bottles, and prohibit smoking in animal contact areas.

- Keep the animal areas as clean and disinfected as possible, and limit visitor contact with manure and animal bedding.
- Allow feeding of animals only if contact with animals can be controlled (e.g., over a barrier).
- Minimize use of animal areas for public (nonanimal) activities.
- Design transition areas for entering and exiting animal areas with appropriate signs or other forms of notification regarding risks and location of hand-washing facilities.
- Maintain hand-washing stations that are accessible to children, and direct visitors to wash their hands when exiting animal areas.
- Position hand-washing stations in places that encourage hand washing when exiting animal areas.
- Ensure that animals receive appropriate preventive care, including vaccinations and parasite control.
- Provide potable water for animals.
- Prohibit consumption of unpasteurized products (e.g., dairy products and juices).

#### **Operators and staff members should educate visitors regarding animal contact in public settings:**

- Provide simple instructions in multiple age- and language-appropriate formats.
- Warn visitors about the risks for disease and injury.
- Direct visitors to wash their hands and assist children with hand washing after contact with animals or visiting an animal area.
- Advise visitors that they should not eat, drink, or place things in their mouths after animal contact or visiting an animal area until they have washed their hands.
- Advise visitors to closely supervise children and to be aware that objects such as clothing, shoes, and stroller wheels can become soiled and serve as a source of germs after leaving an animal area.
- Make visitors aware that young children, older adults, pregnant women, and persons who are immunocompromised are at increased risk for illness.

## Appendix B

### Suggested Sign or Handout for Visitors to Petting Zoos\*

**K**now that animals carry germs that can make people sick

**N**ever eat, drink, or put things into your mouth in animal areas

**O**lder adults, pregnant women, and young children should be extra careful around animals

**W**ash your hands with soap and water right after visiting the animal area

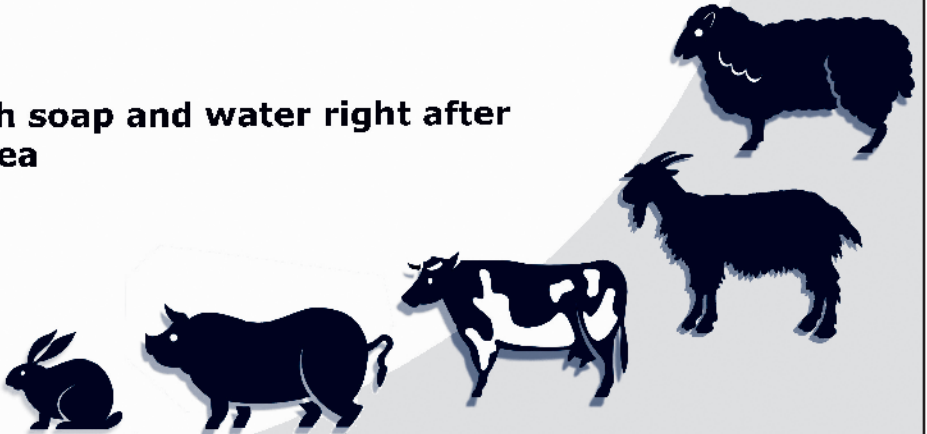

## How to be Safe Around Animals!

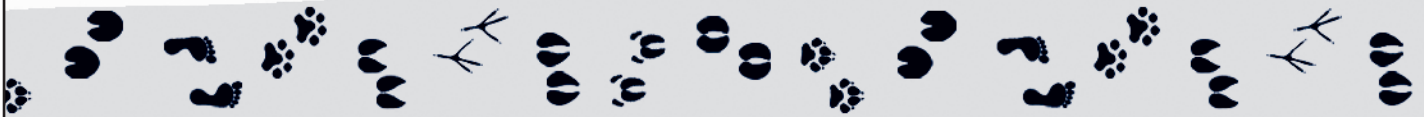

\* Sign available at <http://www.nasphv.org/documentscompendiaanimals.html>. Additional information on animals in public settings and zoonotic diseases is available at <http://www.cdc.gov/healthypets>.

## Appendix C

### Hand-Washing Recommendations to Reduce Disease Transmission from Animals in Public Settings

Hand washing is the most important prevention step for reducing disease transmission associated with animals in public settings. Hands should always be washed when exiting animal areas, after removing soiled clothing or shoes, and before eating or drinking. Venue staff members should encourage hand washing as persons exit animal areas.

#### How to Wash Hands

- Wet hands with running water; place soap in palms; rub hands together to make a lather; scrub hands thoroughly for 20 seconds (e.g., the amount of time it takes to sing the ABC song); and rinse soap off hands.
- If possible, turn off the faucet using a disposable paper towel.
- Dry hands with a disposable paper towel. Do not dry hands on clothing.
- Assist young children with washing their hands.

#### Hand-Washing Facilities or Stations

- Hand-washing facilities or stations should be accessible, sufficient for the maximum anticipated attendance, and accessible by children (i.e., low enough for children to reach or equipped with a stool), adults, and persons with disabilities.
- Hand-washing facilities stations should be conveniently located in transition areas between animal and nonanimal areas and in the nonanimal food concession areas.
- Maintenance of hand-washing facilities and stations should include routine cleaning and restocking to ensure an adequate supply of paper towels and soap.
- Running water should be of sufficient volume and pressure to remove soil from hands. Volume and pressure might be substantially reduced if the water supply is furnished from a holding tank; therefore, a permanent pressurized water supply is preferable.
- Hand-washing stations should be designed so that both hands are free for hand washing by having operation with a foot pedal or water that stays on after hand faucets are turned on.

- Hot water is preferable, but if the hand-washing facilities or stations are supplied with only cold water, a soap that emulsifies easily in cold water should be provided.
- Communal basins, in which water is used by more than one person, are not adequate hand-washing facilities.

#### Hand-Washing Agents

- Liquid soap dispensed by a hand or foot pump is recommended.
- Alcohol-based hand sanitizers (concentration of  $\geq 60\%$ ) may be used if soap and water cannot be made available and the sanitizers are effective against multiple common disease agents (e.g., Shiga toxin-producing *Escherichia coli*, *Salmonella* species, and *Campylobacter* species). However, they are ineffective against some organisms (e.g., bacterial spores, *Cryptosporidium* species, and certain viruses).
- Hand sanitizers are less effective on visibly soiled hands. Therefore, as much visible contamination and dirt as possible should be removed before using hand sanitizers.





#### Hand-Washing Signs

- At venues where human-animal contact occurs, signs regarding proper hand-washing practices are critical to reduce disease transmission.
- Signs that remind visitors to wash hands should be posted at exits from animal areas (i.e., exit transition areas) and in nonanimal areas where food is served and consumed (Figure).
- Signs should be posted that direct all visitors to hand-washing stations when exiting animal areas.
- Signs with proper hand-washing instructions should be posted at hand-washing stations and restrooms to encourage proper practices.
- If appropriate for the setting, hand-washing signs should be available in different languages.

FIGURE. Hand-washing sign\*



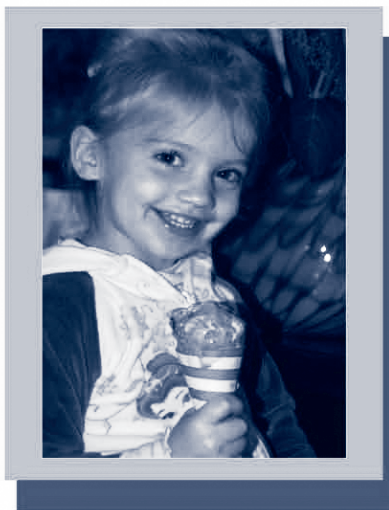

# Directions for Washing Hands

## HOW

-  Wet hands with running water
-  Place soap into palms
-  Rub together to make a lather
-  Scrub hands vigorously for 20 seconds
-  Rinse soap off hands
-  Dry hands with disposable paper towels, not on clothing



## WHEN

- After going to the toilet 
- Upon exiting animal areas 
- Before eating 
- Before preparing foods 
- After removing soiled clothes or shoes 

\* Sign available at <http://www.nasphv.org/documentscompendiaanimals.html>. Additional information on animals in public settings and zoonotic diseases is available at <http://www.cdc.gov/healthypets>.



## Appendix D

### Guidelines for Animals in School and Child-Care Settings

Animals are effective and valuable teaching aids, but safeguards are required to reduce the risk for infection and injury. The following guidelines are a summary of guidelines developed by the Alabama Department of Public Health,\* the Kansas Department of Health and Environment,<sup>†</sup> and CDC (75,76). Recommendations also are available from the National Science Teachers Association<sup>§</sup> and the National Association of Biology Teachers.<sup>¶</sup>

#### General Guidelines for School Settings\*\*

- Wash hands after contact with animals, animal products or feed, or animal environments.
- Supervise human-animal contact, particularly involving children aged <5 years.
- Display animals in enclosed cages or under appropriate restraints.
- Do not allow animals to roam, fly free, or have contact with wild animals.
- Designate specific areas for animal contact.
- Do not allow food in animal contact areas; do not allow animals in areas where food and drink are prepared or consumed.
- Clean and disinfect all areas where animals have been present. Children should only perform this task under adult supervision.
- Do not clean animal cages or enclosures in sinks or other areas used to prepare food and drinks.
- Obtain appropriate veterinary care, a certificate of veterinary inspection, or proof of rabies vaccination (or all of these) according to local or state requirements.
- Keep animals clean and free of intestinal parasites, fleas, ticks, mites, and lice.

- Parents should be informed of the benefits and potential risks associated with animals in school classrooms. Consult with parents to determine special considerations needed for children who are immunocompromised, have allergies, or have asthma.
- Ensure that personnel providing animals for educational purposes are knowledgeable regarding animal handling and zoonotic disease issues. Persons or facilities that display animals to the public should be licensed by the U.S. Department of Agriculture.

#### Animal-Specific Guidelines

- **Fish:** Use disposable gloves when cleaning aquariums, and do not dispose of aquarium water in sinks used for food preparation or for obtaining drinking water.
- **Psittacine birds (e.g., parrots, parakeets, and cockatiels):** Consult the psittacosis compendium,<sup>††</sup> and seek veterinary advice. Use birds treated or that test negative for avian chlamydiosis.
- **Nonpsittacine birds:** See General Guidelines for School Settings.
- **Domestic dogs, cats, rabbits, and rodents (e.g., mice, rats, hamsters, gerbils, guinea pigs, and chinchillas):** See General Guidelines for School Settings.
- **Reptiles (e.g., turtles, snakes, and lizards):** Should not be kept in facilities with children aged <5 years, nor should children aged <5 years be allowed to have direct contact with these animals.
- **Amphibians (e.g., frogs, toads, salamanders, and newts):** To prevent *Salmonella* infection, children aged <5 years should not have direct contact with amphibians.
- **Baby poultry (e.g., chicks, ducklings, and goslings):** Should not be kept in facilities with children aged <5 years, nor should children aged <5 years be allowed to have direct contact with these animals.
- **Ferrets:** To prevent bites, children aged <5 years should not have direct contact with ferrets.
- **Farm animals:** See General Guidelines for School Settings. Certain animals (e.g., young ruminants and baby poultry) intermittently excrete substantial numbers of *Escherichia coli* O157:H7, *Salmonella* organisms, *Campylobacter* organisms, and *Cryptosporidium* organisms; therefore,

\*WB Johnston, DVM, Alabama Department of Public Health, personal communication, 2002.

<sup>†</sup> Hansen GR. Animals in Kansas schools: guidelines for visiting and resident pets. Topeka, KS: Kansas Department of Health and Environment; 2004. Available at <http://www.kdhe.state.ks.us/pdf/hef/ab1007.pdf>.

<sup>§</sup> National Science Teachers Association. Standards for science teacher preparation. Arlington, VA: National Science Teachers Association; 2003. Available at <http://www.nsta.org/main/pdfs/NSTASTandards2003.pdf>.

<sup>¶</sup> National Association of Biology Teachers. The use of animals in biology education. Reston, VA: National Association of Biology Teachers; 2008. Available at <http://www.nabt.org/websites/institution/File/docs/use%20of%20animals.pdf>.

\*\* Guide, hearing, or other service animals and law enforcement animals may be used when they are under the control of a person familiar with the specific animal and in accordance with recommendations from the sponsoring organizations.

<sup>††</sup> National Association of State Public Health Veterinarians. Compendium of measures to control *Chlamydia psittaci* infection among humans (psittacosis) and pet birds (avian chlamydiosis), 2008. Available at <http://www.nasphv.org/documents/psittacosis.pdf>.

these farm animals are not appropriate in school or child-care settings unless meticulous attention to personal hygiene can be ensured.

- **Owl pellets:** Assume that owl pellets are contaminated with *Salmonella* organisms. Pellets should not be dissected in areas where food is consumed. Thoroughly clean and disinfect surfaces that contact pellets. Wash hands after contact.

### **Animals Not Recommended in School or Child-Care Settings**

- Inherently dangerous animals (e.g., lions, tigers, cougars, and bears).
- Nonhuman primates (e.g., monkeys and apes).
- Mammals at high risk for transmitting rabies (e.g., bats, raccoons, skunks, foxes, and coyotes).
- Aggressive or unpredictable wild or domestic animals.
- Stray animals with unknown health and vaccination history.
- Venomous or toxin-producing spiders, insects, reptiles, and amphibians.

The *Morbidity and Mortality Weekly Report (MMWR)* Series is prepared by the Centers for Disease Control and Prevention (CDC) and is available free of charge in electronic format. To receive an electronic copy each week, visit *MMWR*'s free subscription page at <http://www.cdc.gov/mmwr/mmwrsubscribe.html>. Electronic copy also is available from CDC's Internet server at <http://www.cdc.gov/mmwr> or from CDC's file transfer protocol server at <ftp://ftp.cdc.gov/pub/publications/mmwr>. Paper copy subscriptions are available through the Superintendent of Documents, U.S. Government Printing Office, Washington, DC 20402; telephone 202-512-1800.

Data in the weekly *MMWR* are provisional, based on weekly reports to CDC by state health departments. The reporting week concludes at close of business on Friday; compiled data on a national basis are officially released to the public on the following Friday. Data are compiled in the National Center for Public Health Informatics, Division of Integrated Surveillance Systems and Services. Address all inquiries about the *MMWR* Series, including material to be considered for publication, to Editor, *MMWR* Series, Mailstop E-90, CDC, 1600 Clifton Rd., N.E., Atlanta, GA 30333 or to [mmwrq@cdc.gov](mailto:mmwrq@cdc.gov).

All material in the *MMWR* Series is in the public domain and may be used and reprinted without permission; citation as to source, however, is appreciated.

Use of trade names and commercial sources is for identification only and does not imply endorsement by the U.S. Department of Health and Human Services.

References to non-CDC sites on the Internet are provided as a service to *MMWR* readers and do not constitute or imply endorsement of these organizations or their programs by CDC or the U.S. Department of Health and Human Services. CDC is not responsible for the content of these sites. URL addresses listed in *MMWR* were current as of the date of publication.



Morbidity and Mortality Weekly Report

Recommendations and Reports  
May 1, 2009 / Vol. 58 / RR-5

## Continuing Education Activity Sponsored by CDC

### Compendium of Measures to Prevent Disease Associated with Animals in Public Settings, 2009 National Association of State Public Health Veterinarians, Inc. (NASPHV)

**EXPIRATION – May 1, 2011**

You must complete and return the response form electronically or by mail by **May 1, 2011**, to receive continuing education credit. If you answer all of the questions, you will receive an award letter for 1.25 hours Continuing Medical Education (CME) credit; 0.1 Continuing Education Units (CEUs); 1.25 contact hours Continuing Nursing Education (CNE)

credit; or 1.0 credit hour Continuing Veterinary Education (CVE). If you return the form electronically, you will receive educational credit immediately. If you mail the form, you will receive educational credit in approximately 30 days. No fees are charged for participating in this continuing education activity.

#### INSTRUCTIONS

##### By Internet

1. Read this *MMWR* (Vol. 58, RR-5), which contains the correct answers to the questions beginning on the next page.
2. Go to the *MMWR* Continuing Education Internet site at <http://www.cdc.gov/mmwr/cme/conted.html>.
3. Select which exam you want to take and select whether you want to register for CME, CEU, CNE, or CVE credit.
4. Fill out and submit the registration form.
5. Select exam questions. To receive continuing education credit, you must answer all of the questions. Questions with more than one correct answer will instruct you to "Indicate all that apply."
6. Submit your answers no later than **May 1, 2011**.
7. Immediately print your Certificate of Completion for your records.

##### By Mail or Fax

1. Read this *MMWR* (Vol. 58, RR-5), which contains the correct answers to the questions beginning on the next page.
2. Complete all registration information on the response form, including your name, mailing address, phone number, and e-mail address, if available.
3. Indicate whether you are registering for CME, CEU, CNE, or CVE credit.
4. Select your answers to the questions, and mark the corresponding letters on the response form. To receive continuing education credit, you must answer all of the questions. Questions with more than one correct answer will instruct you to "Indicate all that apply."
5. Sign and date the response form or a photocopy of the form and send no later than **May 1, 2011**, to  
Fax: 404-498-2388  
Mail: MMWR CE Credit  
CCHIS, Centers for Disease Control and Prevention  
1600 Clifton Rd, N.E., MS E-90  
Atlanta, GA 30333
6. Your Certificate of Completion will be mailed to you within 30 days.

#### ACCREDITATION

**Continuing Medical Education (CME).** CDC is accredited by the Accreditation Council for Continuing Medical Education to provide continuing medical education for physicians. CDC designates this educational activity for a maximum of 1.25 hours in category 1 credit toward the AMA Physician's Recognition Award. Each physician should claim only those hours of credit that he/she actually spent in the educational activity.

**Continuing Education Unit (CEU).** CDC has been reviewed and approved as an Authorized Provider by the International Association for Continuing Education and Training (IACET), 8405 Greensboro Drive, Suite 800, McLean, VA 22102. CDC will award 0.1 continuing education unit to participants who successfully complete this program.

**Continuing Nursing Education (CNE).** This activity for 1.25 contact hours is provided by CDC, which is accredited as a provider of continuing education in nursing by the American Nurses Credentialing Center's Commission on Accreditation.

**Continuing Veterinary Education (CVE).** CDC has been approved as an authorized provider of veterinary credit by the American Association of Veterinary State Boards (AAVSB) RACE program. CDC will award 1.0 hour of continuing education credit to participants who successfully complete this activity.



## Goal and Objectives

This *MMWR* provides evidence-based guidelines for reducing risks associated with animals in public settings. The recommendations were developed by the National Association of State Public Health Veterinarians, in consultation with representatives from CDC, the National Assembly of State Animal Health Officials, the U.S. Department of Agriculture, the American Veterinary Medical Association Council on Public Health and Regulatory Veterinary Medicine, the Association of Zoos and Aquariums, and the Council of State and Territorial Epidemiologists. The goal of this report is to provide guidelines for public health officials, veterinarians, animal venue operators, animal exhibitors, and others concerned with disease control to minimize risks associated with animals in public settings. Upon completion of this activity, the reader should be able to describe 1) the reasons for the development of the guidelines; 2) the disease risks associated with animals in public settings; 3) populations at high risk; and 4) recommended prevention and control methods to reduce disease risks.

1. **Which one of the following is true about the reasons why these recommendations were developed?**
  - A. Animal contacts are too risky and thus must be regulated against.
  - B. Only petting zoos are of concern for disease risk.
  - C. Multiple venues allow public contact with animals and thus pose a disease risk.
  - D. These recommendations were developed to control zoonoses, which are diseases contracted only at zoos.
  - E. Following these guidelines will eliminate all disease risk.
2. **Which of the following are enteric pathogens that might result in human infection after animal contact?**
  - A. *Escherichia coli* O157.
  - B. *Campylobacter*.
  - C. *Salmonella*.
  - D. *Cryptosporidium*.
  - E. All of the above.
3. **Animals with *E. coli* O157:H7 in their gastrointestinal tract. . .**
  - A. always have fever and diarrhea.
  - B. usually show no signs of illness.
  - C. shed the organism continuously.
  - D. might only shed the organism intermittently.
  - E. B and D.
  - F. A and C.
4. **Based on scientific studies, which of the following factors increase the risk for human enteric infections after animal contact?**
  - A. Inadequate hand-washing facilities.
  - B. Structural deficiencies associated with temporary food-service facilities.
  - C. Poor separation between animal exhibits and food-consumption areas.
  - D. Contaminated or poorly maintained drinking water and sewage/manure disposal systems.
  - E. All of the Above.
5. **Which of the following groups are at higher risk for serious infections from animal contact?**
  - A. Persons with waning immunity (e.g., older adults).
  - B. Children aged <5 years.
  - C. Women who are pregnant.
  - D. Persons who are receiving immunosuppressive therapy.
  - E. All of the Above.
6. **Which of the following are recommendations for animal care and management to reduce the risk for disease from animal contact?**
  - A. Animals in contact with the public should be monitored daily by the owners or caretakers for signs of illness.
  - B. Veterinarians can easily perform screening tests for all diseases of concern and provide treatment to eliminate organism shedding.
  - C. Rabies vaccinations will be successful if provided 1 day before the public contact venue.
  - D. A and B.
  - E. None of the above.
7. **Which one of the following are recommendations for animal areas to reduce the risk for disease from animal contact?**
  - A. The best time to remove manure and soiled bedding is at the end of the event when the animals are removed.
  - B. Removal of animals with *E. coli* O157:H7 in their gastrointestinal tract will eliminate the risk for infection associated with the animal contact venue.
  - C. Ice-cream cones are an ideal container for feeds used by children in feeding animals.
  - D. Animal contacts should be carefully supervised for children aged <5 years to discourage hand-to-mouth contact and ensure appropriate hand washing.
  - E. None of the above.
8. **Which of the following is true about hand-washing recommendations to reduce disease transmission from animals in public settings?**
  - A. Hands must be washed vigorously with soap and running water for at least 2 minutes.
  - B. If no hand sinks are available, use alcohol-based hand-sanitizers.
  - C. Cold water is more effective than warm water.
  - D. A and B.
  - E. All of the above.
9. **Which of the following is true about guidelines for animals in school settings?**
  - A. Baby chicks and ducks are an excellent choice for all children in school settings because of their small size.
  - B. Animals can be allowed in food settings (e.g., a school cafeteria) if they have a health certificate from a veterinarian.
  - C. Animals should not be allowed to roam or fly free, and areas for contact should be designated.
  - D. A and C.
  - E. All of the above.
10. **If no licensed rabies vaccine exists for an animal species on display in a petting zoo, options to manage human rabies exposure risk include. . .**
  - A. using an animal born from a vaccinated mother if it is too young to vaccinate.
  - B. penning the animal each night in a cage or pen that will exclude rabies reservoirs (e.g., bats and skunks).
  - C. asking a veterinarian to vaccinate the animal off-label with a rabies vaccine.
  - D. A and B.
  - E. A, B, and C.
11. **Which best describes your professional activities?**
  - A. Physician.
  - B. Nurse.
  - C. Health educator.
  - D. Office staff.
  - E. Other.

12. I plan to use these recommendations as the basis for ... (Indicate all that apply.)

- A. health education materials.
B. insurance reimbursement policies.
C. local practice guidelines.
D. public policy.
E. other.

13. Overall, the length of the journal report was...

- A. much too long.
B. a little too long.
C. just right.
D. a little too short.
E. much too short.

14. After reading this report, I am confident I can describe the reasons for the development of the guidelines.

- A. Strongly agree.
B. Agree.
C. Undecided.
D. Disagree.
E. Strongly disagree.

15. After reading this report, I am confident I can describe the disease risks associated with animals in public settings.

- A. Strongly agree.
B. Agree.
C. Undecided.
D. Disagree.
E. Strongly disagree.

16. After reading this report, I am confident I can identify populations at high risk.

- A. Strongly agree.
B. Agree.
C. Undecided.
D. Disagree.
E. Strongly disagree.

17. After reading this report, I am confident I can recommend prevention and control methods to reduce disease risks.

- A. Strongly agree.
B. Agree.
C. Undecided.
D. Disagree.
E. Strongly disagree.

18. The learning outcomes (objectives) were relevant to the goals of this report.

- A. Strongly agree.
B. Agree.
C. Undecided.
D. Disagree.
E. Strongly disagree.

19. The instructional strategies used in this report (appendices and figure) helped me learn the material.

- A. Strongly agree.
B. Agree.
C. Undecided.
D. Disagree.
E. Strongly disagree.

(Continued on pg CE-4)

Detach or photocopy.

MMWR Response Form for Continuing Education Credit
May 1, 2009/Vol. 58/No. RR-5
Compendium of Measures to Prevent Disease Associated with Animals in Public Settings, 2009
National Association of State Public Health Veterinarians, Inc. (NASPHV)

To receive continuing education credit, you must
1. provide your contact information (please print or type);
2. indicate your choice of CME, CEU, CNE, or CVE credit;
3. answer all of the test questions;
4. sign and date this form or a photocopy;
5. submit your answer form by May 1, 2011.
Failure to complete these items can result in a delay or rejection of your application for continuing education credit.

Form fields for contact information: Last Name, First Name, Street Address or P.O. Box, Apartment or Suite, City, State, ZIP Code, Phone Number, Fax Number, E-Mail Address. Includes checkboxes for CME, CEU, CNE, and CVE credit.

Fill in the appropriate blocks to indicate your answers. Remember, you must answer all of the questions to receive continuing education credit!

Grid for marking answers (A, B, C, D, E) for questions 1 through 27.

Signature Date / Completed Exam

- 20. The content was appropriate given the stated objectives of the report.**
- A. Strongly agree.
  - B. Agree.
  - C. Undecided.
  - D. Disagree.
  - E. Strongly disagree.
- 21. The content expert(s) demonstrated expertise in the subject matter.**
- A. Strongly agree.
  - B. Agree.
  - C. Undecided.
  - D. Disagree.
  - E. Strongly disagree.
- 22. Overall, the quality of the journal report was excellent.**
- A. Strongly agree.
  - B. Agree.
  - C. Undecided.
  - D. Disagree.
  - E. Strongly disagree.
- 23. These recommendations will improve the quality of my practice.**
- A. Strongly agree.
  - B. Agree.
  - C. Undecided.
  - D. Disagree.
  - E. Strongly disagree.
- 24. The availability of continuing education credit influenced my decision to read this report.**
- A. Strongly agree.
  - B. Agree.
  - C. Undecided.
  - D. Disagree.
  - E. Strongly disagree.
- 25. The *MMWR* format was conducive to learning this content.**
- A. Strongly agree.
  - B. Agree.
  - C. Undecided.
  - D. Disagree.
  - E. Strongly disagree.
- 26. Do you feel this course was commercially biased? (*Indicate yes or no; if yes, please explain in the space provided.*)**
- A. Yes.
  - B. No.
- 27. How did you learn about the continuing education activity?**
- A. Internet.
  - B. Advertisement (e.g., fact sheet, *MMWR* cover, newsletter, or journal).
  - C. Coworker/supervisor.
  - D. Conference presentation.
  - E. *MMWR* subscription.
  - F. Other.

**Correct answers for questions 1–10.**  
1. C; 2. E; 3. E; 4. E; 5. E; 6. A; 7. D; 8. B; 9. C; 10. E.